

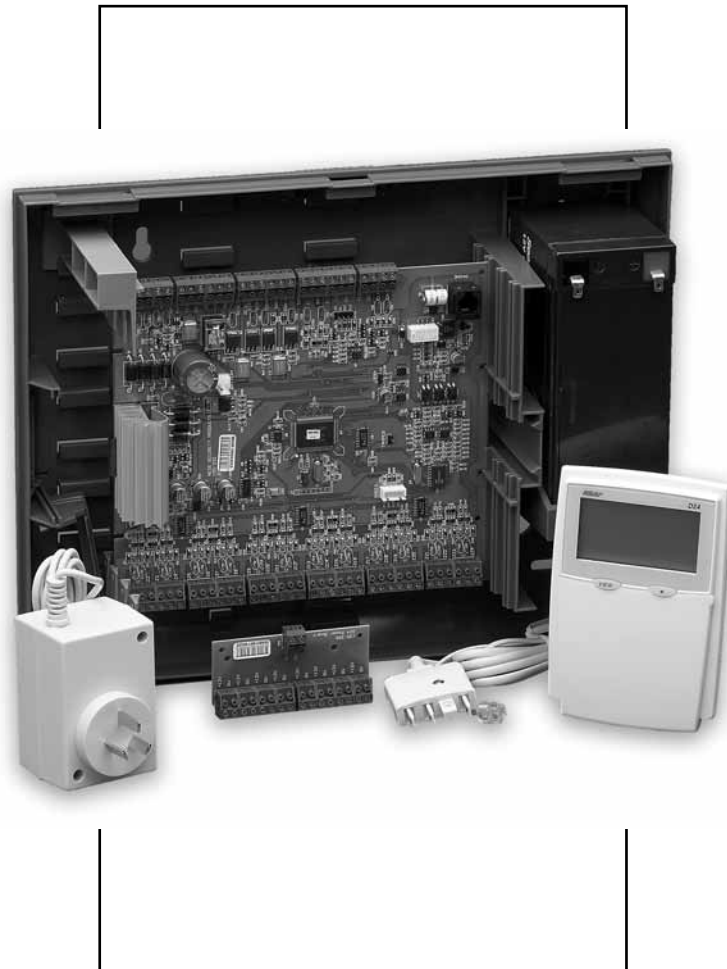

## D 24 CONTROL PANEL AND DIALLER



**INSTALLATION & PROGRAMMING MANUAL**

REV 1.9



**CORPORATION**

Innovative Electronic Solutions  
www.ness.com.au

**NSW** Ph 02 8825 9222  
sales@ness.com.au

**VIC** Ph 03 9875 6400  
nessmelb@ness.com.au

**QLD** Ph 07 3399 4910  
nessbris@ness.com.au

**WA** Ph 08 9328 2511  
nessper@ness.com.au

**SA** Ph 08 8152 0000  
adelaide@ness.com.au

D24 INSTALLER MANUAL  
Rev 1.9 March 2013



Document Part No: 890-253  
For the product 100-660 D24 Control Panel

#### WARNINGS & NOTICES

Ness Corporation manufacturing processes are accredited to ISO9001 quality standards and all possible care and diligence has been applied during manufacture to ensure the reliable operation of this product. However there are various external factors that may impede or restrict the operation of this product in accordance with the product's specification.

These factors include, but are not limited to:

1. Erratic or reduced radio range (if radio accessories are installed). Ness radio products are sophisticated low power devices, however the presence of in-band radio signals, high power transmissions or interference caused by electrical appliances such as Mains Inverters, Wireless Routers, Cordless Phones, Computers, TVs and other electronic devices may reduce radio range performance. While such occurrences are unusual, they are possible. In this case it may be necessary to either increase the physical separation between the Ness receiver and other devices or if possible change the radio frequency or channel of the other devices.
2. Unauthorised tampering, physical damage, electrical interruptions such as mains failure, electrical spikes or lightning.
3. Solar power inverters are a known source of electrical interference. Please ensure that this product and all associated cabling is installed at least 3 metres away from a solar power inverter and its cabling.

**WARNING:** Installation and maintenance to be performed only by qualified service personnel.

**CAUTION:** Risk of explosion if battery is replaced by an incorrect type. Dispose of used batteries in accordance with local regulations.

**ADSL NOTICE:** ADSL broadband data can interfere with the operation of your alarm dialler. It is recommended that a quality ADSL filter be installed as per the filter manufacturer's guidelines in all premises with an alarm dialler installed.

#### COPYRIGHT NOTICE

All rights reserved. No part of this publication may be reproduced, transmitted or stored in a retrieval system in any form or by any means, electronic, mechanical, photocopying, recording, or otherwise, without the prior written permission of Ness.

Ness reserves the right to make changes to features and specifications at any time without prior notification in the interest of ongoing product development and improvement.

© 2012 Ness Corporation Pty Ltd ABN 28 069 984 372

# CONTENTS

Features	4	Mapping Contact ID Channels (P61E–P64E)	31
Specifications	4	Multiple Alarm Reporting (P65E)	32
Installation & Power up procedures	5	Restorals Reporting (P66E)	32
D24 MAIN BOARD WIRING DIAGRAM	6	Mains Fail Reporting Delay (P67E)	32
Wiring examples	7	Zone reporting Abort Delay (P68E, P69E)	33
Inputs	8	Test calls (P70E, P71E)	33
Outputs	9	Easycall dialling (P72E–P74E)	34
D24 LCD KEYPAD	10	Area Client codes (P750E–P753E)	35
<b>QUICK START PROGRAMMING</b>	<b>12</b>	Enable Options (P82E)	35
Program MODE levels	13	NESS RADIO INTERFACE	36
HOW TO ENTER PROGRAM MODE	13	RADIO PROGRAMMING	37
How to EXIT Program Mode	13	Clear Radio Keys (P83E)	37
Master Code (P1E)	14	Program Radio Keys (P831E)	37
User Codes 1–30 (P2E–P030E)	14	Clear Radio Devices (P84E)	37
ENTRY DELAY TIMERS (P17E)	15	Program Radio Devices (P841E)	37
EXIT DELAY TIME (P18E)	15	Medical Delay (P93E)	39
Siren Reset Time (P28E)	15	General Purpose Timer (P94E, P95E)	40
ZONE ASSIGNMENT (P19E–P23E)	16	INSTALLER CODE PROGRAMMING (P99E)	40
Zone Input response time (P252E–P258E)	17	Code Retry Limit (P96E)	41
Vibration Sensitivity (P261E–P268E)	17	Duress Prefix (P97E)	41
Siren Lockout (P291E–P294E)	18	FACTORY DEFAULTS (P981E–P985E)	41
Excludable Alarms (P301E–P304E)	18	OPERATING THE SYSTEM	
AREA PARTITIONING	19	Arming, Disarming	42
Assigning Zones to Areas (P310E–P313E)	19	Arming, Disarming Areas	43
Assigning Monitor Zones (P321E–P322E)	19	Monitor Mode Arming	44
Keypad Shortcuts (P33E)	20	Panic Alarm, Duress Alarm	44
Misc. System Options (P34E)	21	Medical Alarm, Fire Alarm	45
Map zones to output groups (P35xxE–P38xxE)	22	VIEW MENU	46
Map Alarms to output groups (P39xxE–P42xxE)	23	View Memory	47
OUTPUT GROUPS & OUTPUTS, DEFINED	24	Excluding Zones	48
Creating Installer-defined output groups	25	Test Mode	49
Zones with no Exit Delay (P441E)	26	Test Options	49
Test Options (P45E)	26	MONITORING	50
CLIENT CODE (P50E)	27	Central Station Monitoring, Audible Monitoring	50
TELEPHONE NUMBER 1 (P51E)	27	REMOTE OPERATION BY TELEPHONE	51
Telephone Number 2 (P52E)	27	D24 OUTPUT EXPANDER	52
Telephone Number 3 - Callback (P53E)	27	OPTIONS SUMMARY	54–55
REPORTING FORMAT (P54E)	28	INSTALLATION RECORD	56–57
Dialling Format (P55E)	29	CONTACT ID CODES TABLE	58
Alternate Dialling (P57E)	29		
Remote Access Options (P58E)	30		
Required rings to Auto-Answer (P59E)	30		
Open/Close Reporting Options (P60E)	30		

## INTRODUCTION

The D24 alarm control panel is wholly Australian designed and manufactured by Ness Security Products, Australia's largest manufacturer of quality electronic security products. Ness Security Products is a Quality Accredited Company to ISO 9001.

The Ness D24 alarm control panel has been designed to provide you, the security professional, with a 24 zone hardwired (including 8 wireless zones) control panel featuring ease of installation, ease of programming and user friendly operation in a package which is functional and attractive. The design and build of this product is based on the Ness philosophy of excellence without compromise.

Supplied with the D24 LCD Keypad.

### D24 FEATURES

- Powerful multizone commercial security
- 24 fully programmable zones
- 30 User Codes
- Up to 8 Radio Zones
- Contact ID Dialler Format
- Ness Audible Voice Dialler Format
- Separate 24 Hour Tamper input
- Single or Double Trigger Zones
- Remote LCD Keypads (Max 3)
- Optional 4 wire 24hr Zone Tamper using dual EOL resistors
- Programmable Inputs to activate selectable Outputs (Output Mapping)
- Inbuilt Vibration Sensor Analyser
- All programming data is permanently stored in a non-volatile EEPROM memory
- True Dynamic Battery Test every time the Panel is Armed / Disarmed and every hour
- Area Partitionable (3 Areas). Any Zone can be programmed to any area, as well as common areas
- Two separate Monitor Modes (Home Mode)
- Outputs are separately fused with Automatic Reset Fuses
- Day Mode feature.
- 30 Event Memory
- Supports 8 Radio Devices (Radio PIRs, Radio Reeds etc)
- Supports 8 Radio Keys
- All inputs and outputs are heavily protected against lightning and high voltage supply transients. An earth terminal is provided for extra protection
- Comes complete with an AC plug pack and supports a 12V 7Ah battery to maintain system security under all power supply conditions
- Manufactured with the latest SMD Technology
- Ultra-Modern and Impact resistant housing

### D24 SPECIFICATIONS

Construction.....	3mm Polycarbonate (equiv. 1.2mm mild steel)
Dimensions .....	350W x 270H x 120D mm
Plug Pack .....	240V AC, output 17V AC @1.4A
Power Supply.....	13.8V DC @ 800mA
Quiescent Current.....	80mA with 1 Keypad
Operating Voltage .....	9.5V–14V DC
Rechargeable Battery .....	12V 7.0 Amp/hour, lead acid
Battery Charging current .....	350mA maximum, current limited
Dynamic Battery Test .....	Every Hour and on arming 10.75V with a 5 amp load
Fuses.....	2 Amp resettable / sirens & reset. 500mA resettable / 12 volt auxiliary outputs 200 mA resettable / strobe output

### INPUTS

Zones .....	24 physical zone inputs 2 physical 24hr Tamper inputs
End of line resistor: .....	1 x 2200 Ohm (2.2K) without Zone Tamper 2 x 4700 Ohm (4.7K) with Zone Tamper
Remote Keypad data .....	Proprietary 4 wire
Maximum Keypads .....	3
J3 Header.....	Multi-pin connector for the Ness Radio Interface (100-200)

### OUTPUTS

AUX .....	Open Collector output, sink current 50mA
Relay .....	Changeover relay contacts rated 2A @ 24V
Siren A.....	On board siren driver. Timed output.
Siren B.....	On board siren driver. Timed output. (Maximum 3 x 8 Ohm horn speakers over both outputs).
Strobe.....	12V DC latching output. Maximum 2 x 1 Watt strobe lights
Reset .....	12V DC timed output. Maximum 3 x 12V piezo screamers
Equipment power output .....	13.8V DC output for powering detectors and other equipment. Maximum 500mA.

### PACKING LIST 100-660 Ness D24 Control Panel

1	D24 main board	1	Installer manual (optional)
1	D24 Power Board	30	2.2K End Of Line resistors
1	D24 housing	54	4.7K End Of Line resistors
1	Ness D24 LCD keypad	1	Lead assembly - Battery
1	17VAC plug pack	1	Lead assembly - Internal Tamper
1	12V 7Ah battery (optional)	1	Lead assembly - Dialler
1	User manual (optional)	1	Zone list label

## INSTALLATION & POWER UP PROCEDURES

The control panel housing should be mounted in a location that is within a protected zone of the premises.

Install the D24 panel as follows:

### POWERING UP

After wiring, power up as follows:

1. Make sure the J1 pins are open, (remove the link or unseal the lid tamper switch.) This condition forces the panel to enter installer program mode on power up.
2. Connect the battery, (observe correct polarity), and connect the plug pack.
3. The keypad will give 3 beeps and the panel will be in Installer Program mode, (Program icon is flashing).
4. Replace the J1 link or seal the lid tamper.
5. Program the panel as required.

Note 1: The panel will not exit program mode unless User Code 1 (P1E) is programmed, all other programming options are optional.

Note 2: If the J1 link is open (or lid tamper unsealed) when you exit program mode, the tamper alarm will trigger.

### INSTALLATION

1. Insert the Rear Tamper Switch in the mounting hole in the base.
2. Screw the base to the wall using at least 4 fasteners. If mounting on an uneven surface, make sure the rear tamper switch is correctly pushing in.
3. Insert the adjustable Board Clip Retainers in the positions as shown.
4. Insert the D24 Board. Fit the Slots "A" first, followed by slots "B". The board should be mounted in the second highest position.
5. Attach the supplied Speed Nuts to both Bolt Posts.
6. Fit the removable terminal strips on the two rows of pins on the D24 Board.
7. Fit the Housing Lid Tamper Switch behind the right hand bolt post.
8. Connect both tamper switches using the tamper leads supplied and plug the tamper lead assembly into the J1 header on the D24 board.
9. Fit the backup battery in the battery cradle. The battery terminals should be at top.
10. Complete the wiring of detection devices, sirens, telephone lead, etc.
11. Power up and program the control panel.
13. Before exiting program mode, fit the housing lid. Clip the lid at the top first then swing it down. Fasten the lid with the 2 bolts supplied. (The bolts can be made captive to the lid using the supplied circlips).

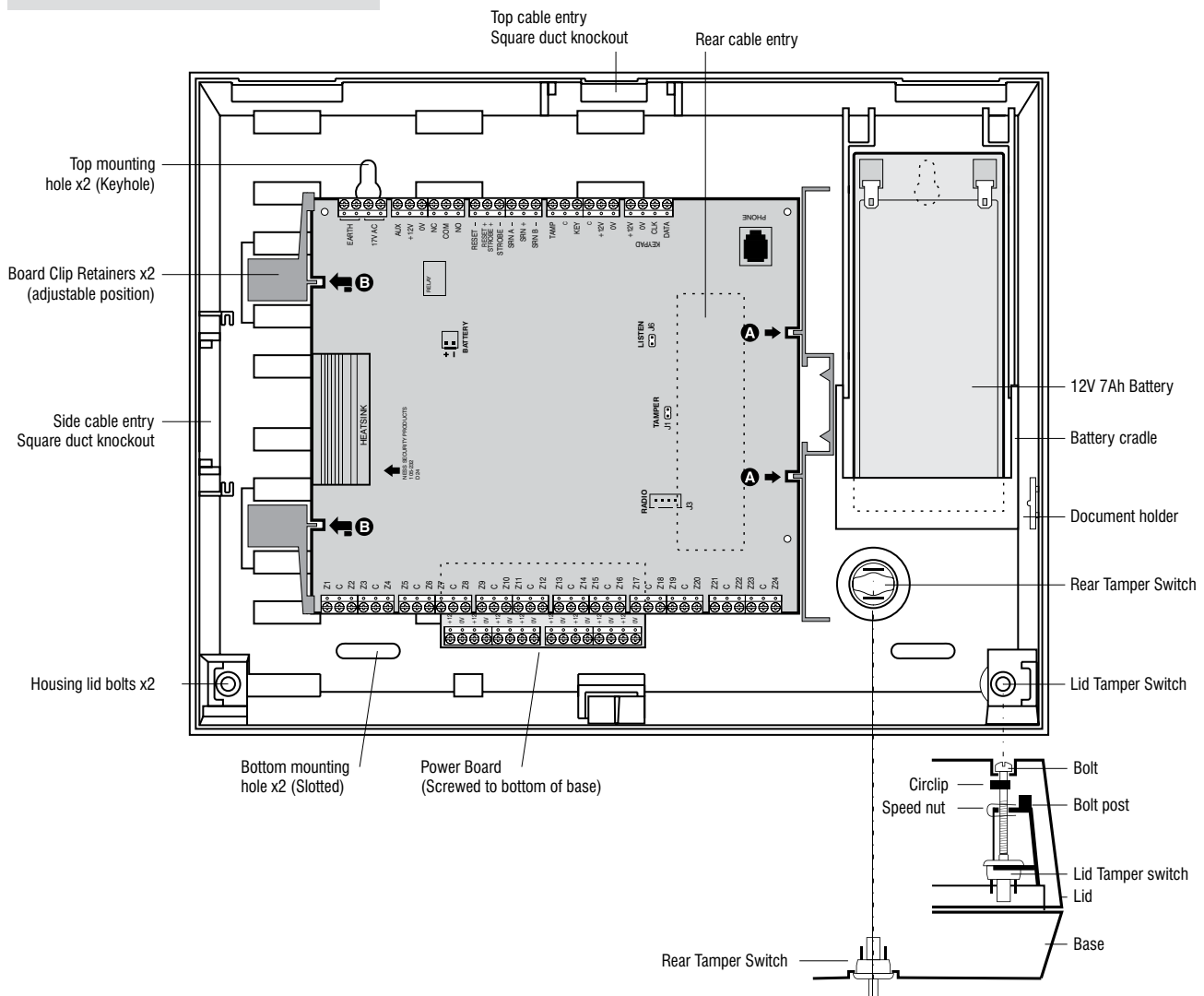

© 2001 Ness Security Products  
D24 Main Board Wiring

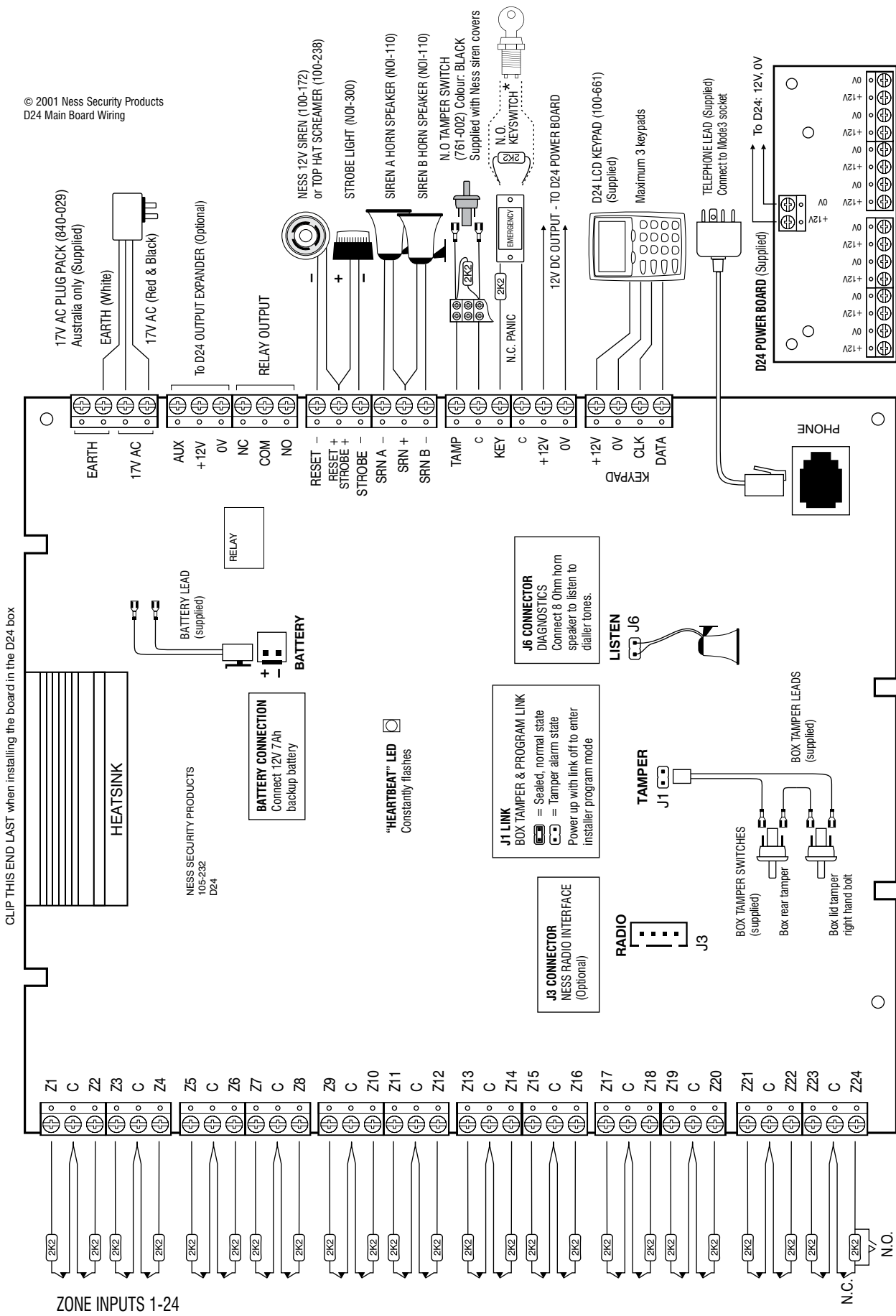

Multiple 12V DC outputs for detectors and other equipment

\* The KEY input is the 24hr Panic input by default.  
Program P400E 1E to enable KEY input as the Keyswitch input. See page 23.

CLIP THIS END LAST when installing the board in the D24 box

CLIP THIS END FIRST when installing the board in the D24 box  
(THIS END CLOSEST TO THE BACKUP BATTERY)

**ZONE TAMPER DISABLED** P34E 6E is ON

**ZONE TAMPER ENABLED** P34E 6E is OFF

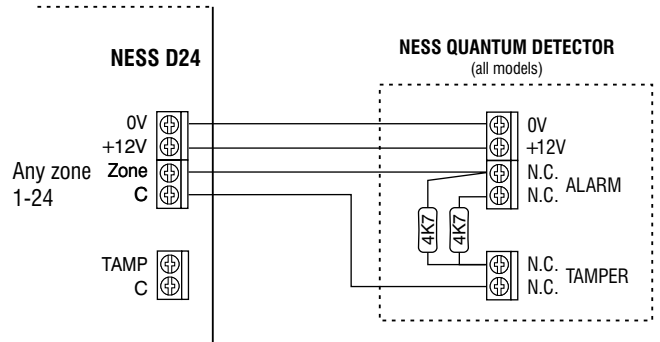
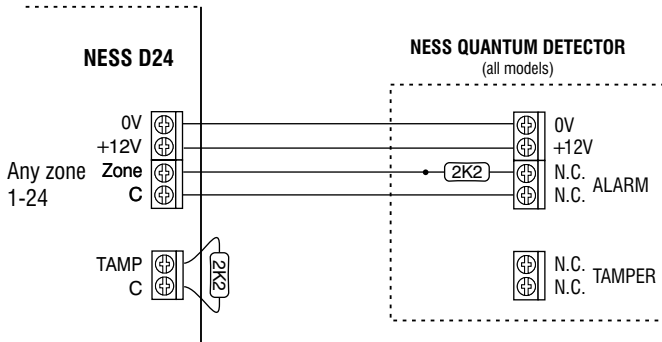
**DETECTORS - 4 WIRE CONNECTION, NO TAMPER**
**DETECTORS - 4 WIRE CONNECTION WITH ZONE TAMPER**

When Zone Tamper is enabled, the zones are sealed with two 4K7 resistors which allow monitoring of both Alarm and Tamper on each zone input over 4 wires.

Zone Tamper looks for these resistances:  
 ZONE SEALED: 2K2  
 ZONE ALARM: 4K7  
 TAMPER ALARM: OPEN CIRCUIT

**NOTE:** When Zone Tamper is enabled, (P34E 6E = off), then all zones must be wired as shown above, otherwise zone alarms will be interpreted as tamper alarms.

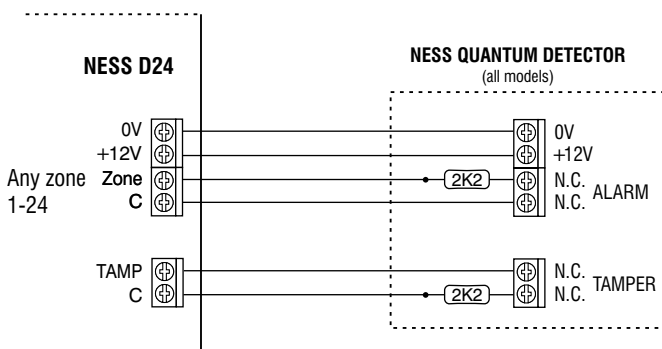
**DETECTORS - 6 WIRE CONNECTION, WITH TAMPER**

**SIREN WIRING**
**EXTERNAL**
**INTERNAL**

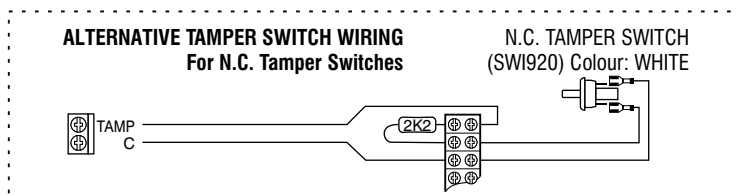
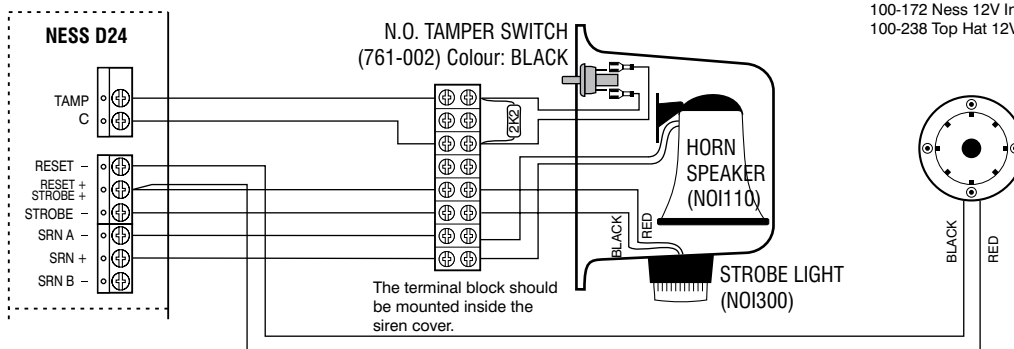
ALTERNATIVE 12V SIRENS:  
 100-172 Ness 12V Internal Siren  
 100-238 Top Hat 12V Piezo Screamer



## INPUTS

### INSTALLERS' TIP

Testing Zone Inputs - when troubleshooting your zone wiring, the voltages across the zone input can help determine the wiring fault.

Correct zone voltages as follows:

#### WITHOUT ZONE TAMPER (FACTORY DEFAULT)

One 2K2 resistor per input

Zone is Sealed:  $4V \pm 0.4V$

Zone is short circuit: 0V

Zone is Open circuit:  $8V \pm 0.4V$

#### WITH ZONE TAMPER

2 x 4K7 resistors per input providing zone alarm and zone tamper

Zone is Sealed:  $4V \pm 0.4V$

Zone is Unsealed:  $5.4V \pm 0.4V$

Zone is short circuit: 0V

Zone is Open circuit:  $8V \pm 0.4V$

Zone tamper is available in D24 V1.5 and later.

### ZONE INPUTS 1-24

The Ness D24 has 24 End Of Line monitored zone inputs. Each zone input must be terminated with a 2K2 (2200 ohm) End Of Line (EOL) resistor as supplied.

If Zone Tamper is enabled (P34E 6E off), the zones are sealed with two 4K7 resistors which allows monitoring of Alarm and Tamper states over 4 wires for each input.

The zone input can be individually programmed for various alarm types including Instant, Delayed, 24hr, Area, Monitor, Fire.

All inputs must be sealed with an EOL resistor even if unused.

For wiring details of Keypads, Keyswitches, Panic Buttons and Warning devices, see the wiring diagrams in the wiring section of this manual.

### TAMP - Tamper Input

The TAMP input must also be sealed with a 2K2 end of line resistor. This input is always a 24hr input.

### KEY - Keyswitch Input

This a 24hr Panic input or an optional keyswitch input for Arming/Disarming.

NOTE: By default, the KEY input is a Panic input. **To use the KEY input as a keyswitch input, program P400E 1E**, (this maps the input to Output Group zero, which disables it as a zone).

### 17 V AC TERMINALS

These terminals are for the connection of the Ness plug-pack. The Ness D24 requires an AC transformer rating of 1.4 Amps @ 17V AC minimum. (Ness Part No. POW215)

### EARTH

For maximum protection against damage caused by lightning strikes, connect a good earth to this terminal. Alternatively use the Earth lead from the plug pack.

### BATTERY

These terminals are for the connection of a sealed lead-acid rechargeable 12Volt battery. Charge current is limited to 350mA. The charge voltage is factory preset at 13.8V. A 12 Volt sealed lead acid rechargeable battery must be connected for correct panel operation. Observe correct polarity when connecting the battery. (Ness Part No: BAT210, 12V 7Ah battery)

### J1 TAMPER - Internal Tamper Input & Program Link

The J1 link has two purposes:

1. **To enter Installer Program Mode on initial power up.** Power up with the J1 link OFF.

*The J1 link must be ON in operating mode. (Or, if using J1 for housing tamper, the tamper switch/es must be sealed).*

2. **Housing Tamper.** When used with the Internal Tamper Lead (supplied), J1 serves as the 24hr tamper input for the panel's internal tamper switch.

Replace the J1 link with the Internal Tamper Lead and tamper switches.

*An EOL resistor is NOT required on this input.*

When J1 is used for internal tamper, powering up with the panel's lid open will enter Installer Program Mode.



## OUTPUTS

### OUTPUT FUSING

The 12V outputs, Siren, Reset and Strobe outputs are protected by Automatic Reset electronic fuses. These outputs will automatically reset once the overload is removed.

### BACKUP BATTERY

A properly charged battery **MUST** be installed to ensure the Siren, Strobe and Reset outputs operate correctly.

### SIREN LOAD

A maximum output of 2.0A continuous is available from the SIREN, and RESET outputs and 200mA from the STR output.

Recommended maximum power load:

- 3 x Horn speakers total (SRN A and SRN B)
- 2 x Strobe lights (STR output)
- 2 x Ness Internal Sirens (100-172) (RESET output)

**Note:** (This assumes no more than 500mA is being drawn from the 12V device output).

### AUX

The AUX output is a programmable Open Collector output suitable for LEDs, Relays, etc. This output can sink a total of 50mA.

### +12V, 0V OUTPUT (x3)

A regulated 13.8 VDC output is available to power detectors and other equipment. This output is available from three sets of terminals marked +12V and 0V. The output is protected by an Automatic Reset fuse.

The three sets of 12V outputs can be used to power:

1. The Output Expander board (optional).
2. The D24 Power Board (supplied) and all equipment off the Power Board.
3. The D24 keypad (supplied).

A maximum load of 500mA in total can be connected to these terminals.

### RELAY

The relay is a programmable output providing a set of dry changeover contacts (N.C. COM. N.O.) with a contact rating of 2A @ 24V.

### RESET-

A 12V DC output for connecting Ness Sirens, piezo sirens or relays, etc. This output will reset at the end of Siren Reset Time (P28E) or whenever the panel is reset.

A maximum of 3 x 12V piezo Sirens (Ness Part No. NOI240, NOI 230, 100-238) or 2 X Ness Piezo (Part No 100-172) can be connected to this output. The output is protected by an Automatic Reset fuse.

### STROBE-

A latched 12VDC output for connecting strobe lights. This output will latch on in the event of an alarm condition and stay on until the panel is reset.

A maximum of 2 x 1 Watt Strobes (Ness Part No. NOI300) can be connected to this output. The output is protected by an Automatic Reset fuse.

### SIREN A (SRN A-)

Siren driver output for connecting horn speakers (Ness Part No. NOI110 or 100-171 Internal Siren). The output will reset at the end of siren time (P28E) or whenever the panel is reset, whichever comes first. This output has an internal Resettable fuse.

### SIREN B (SRN B-)

Second siren driver output. Same specifications as Siren A.

When by operating the D24 by optional Radio Key or optional Keyswitch, Siren B will chirp to provide Arming/Disarming feedback, (if P34E 2Eis enabled).

#### Siren Chirps

ARMING: 1 Chirp from Siren B.

DISARM: 2 Chirps from Siren B.

### MAXIMUM NUMBER OF HORN SPEAKERS

The D24 supports a maximum of 3 x 8 Ohm horn speakers across SRN A and SRN B. E.g., SRN A, 2 horn speakers. SRN B, 1 horn speaker.

### J6 LISTEN LINK

Installer's diagnostic output. Connect an 8 ohm horn speaker to listen in to dialler tones.

### KEYPAD

+12V, 0V, CLK, DATA for connecting up to 3 Ness D24 LCD keypads connected in parallel.

The maximum recommended cable run is 100m for 1 keypad using 14/0.20 cable. Each additional keypad will reduce the maximum cable distance accordingly.

# KEYPAD

## D24 LCD KEYPAD

The Ness D24 LCD keypad provides important visual and audible indication of the system status and is the main interface for controlling the many powerful features of the D24 system.

Information is displayed on a large LCD icon display which is backlit for easy night viewing.

### NUMBER OF KEYPADS

Up to **3 LCD keypads** can be connected to the D24.

### CABLE LENGTH

The maximum allowable **cable length** is 100m (total cable length to all keypads). Use at least 14/020 stranded cable or heavier.

The keypad/s may not work correctly if the cable runs to the keypad/s are too long or the cable used is too thin. A 2k2 resistor added across DATA & +12 at the control panel may improve keypad data comms in such cases. We stress the importance of heavy cable to the keypads and you should run extra pairs to double up for power if required.

### DISPLAY TEST

To display all the keypad icons press and hold the (E) button for at least 2 seconds. All the icons will be on whilst the (E) button is held down.

The display test can be activated at any time either in operating mode or any program mode.

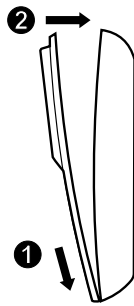





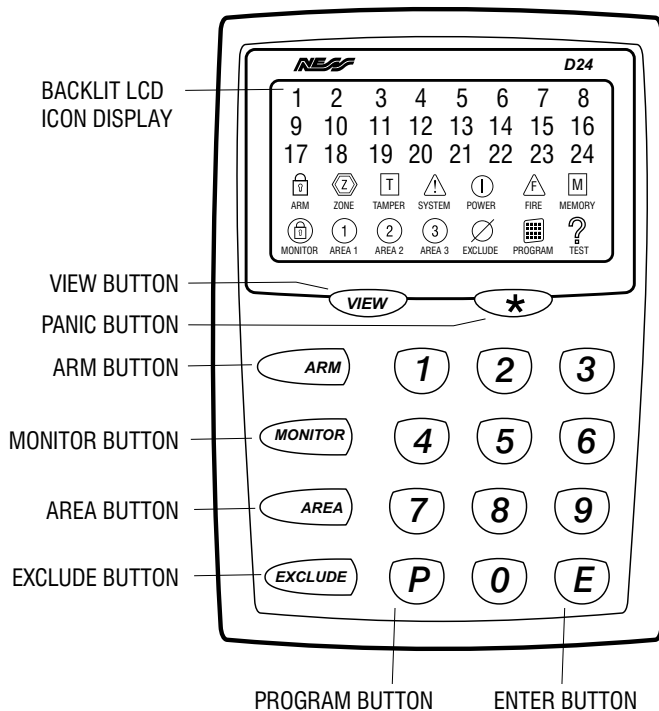









### KEYPAD INSTALLATION



1. Unclip the top half of the keypad housing by pushing the top clips down with a small screwdriver and pulling the housing forward.
2. Screw the base of the keypad housing to the wall using the 4 mounting holes provided.
3. Bring the 4 connecting wires to the terminal block on the PCB on the rear of the keypad housing.
4. Connect the wires to the screw terminals as per the wiring diagram shown in this manual.
5. Clip the top half onto the base by first engaging the bottom clips and swinging the top closed. Push hard to ensure the clips engage.
6. Attach the Zone list label on the inside of the lid.





## KEYPAD DISPLAY Table

## VIEW Menu Operation

	OFF	ON	Flashing FAST	Flashing SLOW
<b>ZONES 1-24</b>	Zone sealed	Zone unsealed	Zone Alarms present (in Armed or Monitor Mode)	
 <b>ARM</b>	Panel is Disarmed	Panel is Armed		
 <b>ZONE</b>		Displaying Zone Status		
 <b>TAMPER</b>	Normal	Displaying individual Tamper Alarms	Tamper Alarms present	
 <b>SYSTEM</b>	Normal	Displaying individual System Alarms	System Alarms present	
 <b>POWER</b>	Normal	Displaying individual Power Alarms	Power Alarms present	
 <b>FIRE</b>	Normal	Fire warning (If enabled)	Fire alarm (If enabled)	
 <b>MEMORY</b>	Normal	Memory Mode or View key pressed	New alarm in Memory	
 <b>MONITOR</b>				Panel is in Monitor Mode
 <b>AREA 1</b>		Area 1 Armed		Area 1 Monitor
 <b>AREA 2</b>		Area 2 Armed		Area 2 Monitor
 <b>AREA 3</b>		Area 3 Armed		
 <b>EXCLUDE</b>		Exclude Mode		Zone or other alarm Excluded
 <b>PROGRAM</b>	Normal	User Program Mode		
 <b>TEST</b>	Normal	Siren Test		

To view **TAMPER** alarms  
  

- ### TAMPER ALARMS
- 1 External Tamper
  - 2 Control Panel Tamper
  - 3 Zone input Tamper
  - 5 Radio Interface Tamper





To view **SYSTEM** alarms  
  

- ### SYSTEM ALARMS
- 1 Keyswitch Panic
  - 2 Dialler line fault
  - 3 Keypad connection fault
  - 4 Control Panel fault
  - 5 Duress alarm
  - 6 Panic alarm
  - 7 Medical alarm
  - 8 User Code alarm
  - 9 Radio Supervision alarm
  - 0 RK4 Radio Key Aux button

To view **POWER** alarms  
  

- ### POWER ALARMS
- 1 Mains power failure
  - 2 Backup Battery low
  - 3 DC supply failed
  - 4 Zone reference supply failed
  - 9 Radio Device battery low
  - 0 Radio Key battery low

To view **MEMORY**  
 

- ### MEMORY DISPLAY
- MEMORY icon flashes to indicate that Memory contains new events. Memory can be viewed at any time.
1. Press  
  2.  Memory icon turns on  
*Keypad icons will display the most recent event as per the Keypad Display Table*
  3. Step through the Memory display by pressing the  button. At each step, the keypad icons display the history of Arming, Disarming and alarm events.  
*Press  to cancel the Memory display at any time*

# PROGRAMMING

## QUICK START PROGRAMMING FROM POWER-UP

The D24 comes programmed with factory default values that should suit most average installations.

The steps below will show you how to program the Master Code (User Code 1) and the Client Code and telephone number for central station monitoring.

The installation must be complete - all zones wired and sealed, tampers connected, keypad wired.

### PROGRAMMING SEQUENCE:

**1 To enter Installer Program Mode**

Power up the panel with the J1 link removed, or with the box lid open if using the Tamper Lead Assembly. (See Main Board Wiring Diagram, page 6).



The PROGRAM light will be flashing

**2 To program the Master Code**

Example Master Code is 1234.

Press **P 1 E 1 2 3 4 E 1 2 3 4 E**  
P1E is the option for the Master Code      Enter the new Master Code followed by E      Enter the new Master Code again followed by E

**3 To program the dialler Client Code**

Example Client Code is 9876.

Press **P 5 0 E 9 8 7 6 E**  
P50E is the option for the Client Code      Enter the new Client Code

The keypad display will flash out the new code.

**4 To program the central station telephone number**

Example telephone number is 1234 7890.

Press **P 5 1 E 1 2 3 4 7 8 9 0 E**  
P51E is the option for Telephone Number 1      Enter the new telephone number followed by E

The keypad display will flash out the new telephone number.

**5 To exit Installer Program Mode**

Press **P** followed by **E**

The PROGRAM light will turn off.

**THE PANEL IS NOW PROGRAMMED AS FOLLOWS:**

Master Code:..... **1234**.....Example only  
 Dialler Client Code: ..... **9876**.....Example only<sup>1</sup>  
 Telephone number:..... **1234 7890** .....Example only<sup>1</sup>  
 Dialler reporting format..... **Contact ID** .....Factory default  
 Zone 1 ..... **Delay / Dialler /Sirens** .....Factory default  
 Zone 2 ..... **Handover / Dialler /Sirens** .....Factory default  
 Zones 3–24..... **Instant / Dialler /Sirens** .....Factory default  
 Entry Delay Time..... **20 seconds** .....Factory default  
 Exit Delay Time ..... **60 seconds** .....Factory default  
 Siren Reset Time..... **10 minutes** .....Factory default

<sup>1</sup> The client code and telephone numbers are normally allocated by the central station.

# PROGRAMMING

## PROGRAM MODE LEVELS

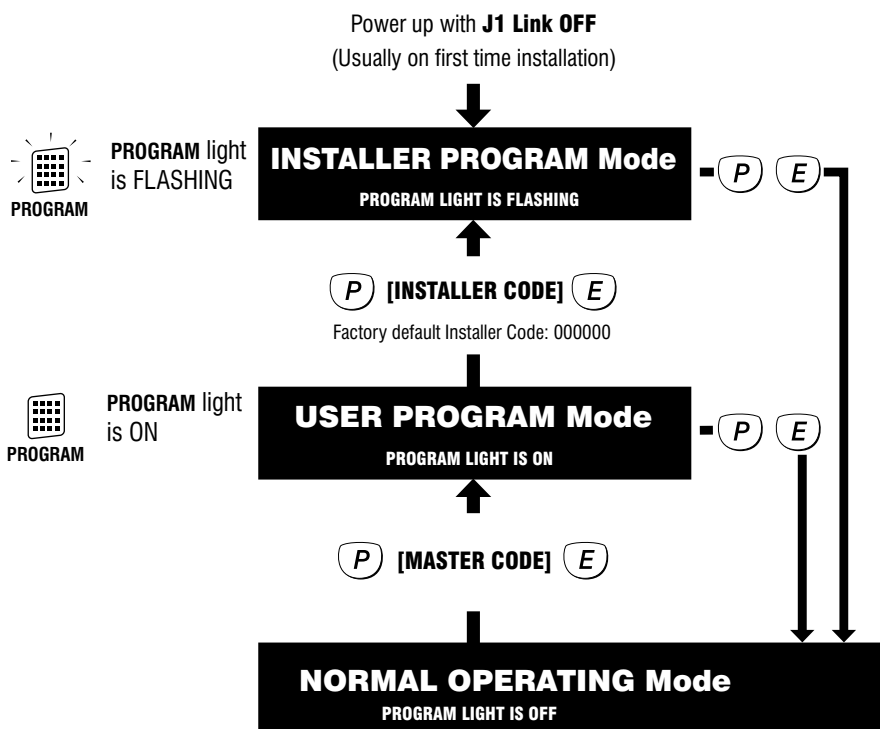

### FACTORY DEFAULT

Master Code: [blank]  
Installer Code: 000000

### INSTALLER PROGRAM MODE

Installer Program Mode allows access to ALL program options.

Note: The panel will remain in Installer Program Mode indefinitely.

### USER PROGRAM MODE

User Program Mode allows the owner to program:

- All User Codes
- Entry and Exit times

Note: The panel will automatically drop out of User Program Mode to Operating Mode if no keypad buttons are pressed for 1 minute.

## HOW TO ENTER PROGRAM MODE



### A FROM POWER UP

1. Power-up with the J1 link OFF.

*The J1 link must be ON in operating mode. (Or, if using J1 for housing tamper, the tamper switch/es must be sealed).*

### B USING THE KEYPAD

The panel must be Disarmed.



1. Press (P) [MASTER CODE] (E) The keypad will respond with 3 beeps. This is User Program Mode (PROGRAM light is ON).
2. Then press (P) [INSTALLER CODE] (E) The keypad will respond with 3 beeps. This is Installer Program Mode (PROGRAM light is FLASHING).

## HOW TO EXIT PROGRAM MODE

1. Press (P) then (E)  
This is Operating Mode (PROGRAM light is OFF).

**THE PANEL WILL NOT EXIT PROGRAM MODE UNLESS USER CODE 1 (P1E) IS PROGRAMMED.**

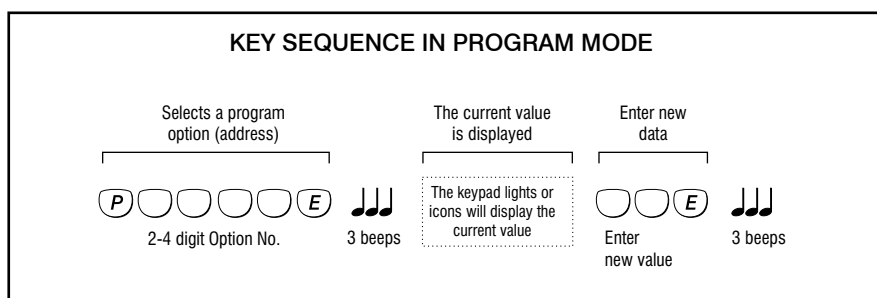

# PROGRAMMING

## P1E – P030E

**PROGRAM MODE LEVEL:**

User, Installer, Remote by PC

**FACTORY DEFAULT:**

[blank]

**TO PROGRAM:**

P [Option No] E [new code] E [new code] E

**NOTES:**

- User Codes can be 3 to 6 digits in length.
- User codes cannot start with '0'.
- All codes must be unique to each other.
- The panel is supplied with NO user codes programmed.
- To delete a code, re-program the code as 000. e.g, To Delete User Code 2: P2E 000E 000E
- To clear all codes, enter P982E in Installer Program mode. See Page 41.
- Codes are rejected if already used. Some codes that are similar to existing codes may also be rejected.
- Open/Close reports are identified by user number when the control panel is central station monitored.

**RELATED OPTIONS:**

Program Installer Code, page 40

OPTION No	USER CODE	DEFAULT
P1E	User Code 1 (Master Code)	
P2E	User Code 2	
P3E	User Code 3	
P4E	User Code 4	
P5E	User Code 5	
P6E	User Code 6	
P7E	User Code 7	
P8E	User Code 8	
P9E	User Code 9	
P10E	User Code 10	
P11E	User Code 11	
P12E	User Code 12	
P13E	User Code 13	
P14E	User Code 14	
P15E	User Code 15	
P16E	User Code 16	
P017E	User Code 17	
P018E	User Code 18	
P019E	User Code 19	
P020E	User Code 20	
P021E	User Code 21	
P022E	User Code 22	
P023E	User Code 23	
P024E	User Code 24	
P025E	User Code 25	
P026E	User Code 26	
P027E	User Code 27	
P028E	User Code 28	
P029E	User Code 29	
P030E	User Code 30	

### USER CODES 1-30

User codes are the P.I.N. codes used to operate various panel functions, especially Arming and Disarming. There are 30 User Codes and each can be 3 to 6 digits long.

User Code 1 is always a MASTER CODE.

User Codes 2 to 30 can be programmed as one of the types: ORDINARY, ADMINISTRATOR, AREA or MASTER.

When programming codes, the User Code type is indicated by the icons:



If User Code 1 was used to enter Program Mode, the digits of any existing codes will be displayed when programming a User Code.

#### ORDINARY CODE & ADMINISTRATOR CODE

An Ordinary Code is for systems configured without Areas. Allows full access to the panel except for entry to Program Mode. (When the panel is partitioned this code is called the Administrator Code).

An Administrator Code is able to Arm and Disarm all Areas of a Partitioned system, but it is not allowed entry to Program Mode.

To Program an Ordinary Code or Admin Code: (P) [OPTION] (E) [CODE] (E) [CODE] (E)

The ARM AREA 1 AREA 2 AREA 3 icons will be ON.

#### AREA CODE

An Area Code is a code which only has access to the Area assigned to it.

To Program: (P) [OPTION] (E) [AREA No.] (E) [CODE] (E) [CODE] (E)

One of the icons AREA 1 or AREA 2 or AREA 3 will be ON, depending on [Area No.] entered.

#### MASTER CODE

A Master Code is able to Arm and Disarm all Areas of a Partitioned system and is allowed entry to Program Mode. User Code 1 is always a Master Code, but all other codes can be programmed as Master Codes if needed.

To Program: (P) [OPTION] (E) 0 (E) [CODE] (E) [CODE] (E)

The ARM AREA 1 AREA 2 AREA 3 icons will be FLASHING.

#### EXAMPLES:

Program User Code 1, the permanent Master Code, to be 1234: **P1E 1234E 1234E**

Program User Code 2 to be 789 and an Ordinary Code: **P2E 789E 789E**

Program User Code 3 to be 5678 and an Area 1 Code: **P3E 1E 5678E 5678E**

Program User Code 4 to be 222 and an Area 2 Code: **P4E 2E 222E 222E**

Program User Code 5 to be 8990 and an Area 3 Code: **P5E 3E 8990E 8990E**

#### PROGRAMMING FEEDBACK

When programming user codes, the existing code and then the new code is 'read back' by flashing the numeric keypad icons 0-9.

1. Press: **P [Option No] E** the existing code is displayed by the keypad.
2. Enter the new code (3 to 6 digits): **[New code] E**
3. Enter the new code again: **[New code] E**, the new code will be displayed.

NOTE: After step 1, the new code can be entered immediately without waiting for the display to finish the 'read back'.

# PROGRAMMING

## PROGRAMMING FEEDBACK

When programming timers, the existing time and then the new time is 'read back' by flashing the numeric keypad icons 0-9.

1. Press: **P [Option No] E** the existing time is displayed by the keypad.
2. Enter the new time: **[New time] E**, the new time will be displayed.

*NOTE: The new time can be entered immediately without waiting for the display to finish the 'read back'.*

## P17E – P173E

### PROGRAM MODE LEVEL:

User, Installer, Remote by PC

### FACTORY DEFAULT:

see table

### TO PROGRAM:

**P [Option No] E [New time] E**

### EXAMPLE:

To program 30 sec Global Entry Delay: **P17E 30E**

### NOTES:

- All timers are programmable from 1-99 seconds

## P18E – P183E

### PROGRAM MODE LEVEL:

User, Installer, Remote by PC

### FACTORY DEFAULT:

see table

### TO PROGRAM:

**P [Option No] E [New time] E**

### EXAMPLE:

To program 55 sec Global Exit Delay:  
**P18E 55E**

### NOTES:

- All timers are programmable from 1-99 seconds

## P28E

### PROGRAM MODE LEVEL:

Installer, Remote by PC

### FACTORY DEFAULT:

10 Minutes

### TO PROGRAM:

**P [Option No] E [New time] E**

### EXAMPLE:

To program 5 minute Siren Time:  
**P28E 5E**

OPTION No	DESCRIPTION	DEFAULT
<b>P17E</b>	Entry Delay Time	20 Seconds
<b>P170E</b>	Entry Delay Time for zones in multiple areas	20 Seconds
<b>P171E</b>	Entry Delay Time for AREA 1	20 Seconds
<b>P172E</b>	Entry Delay Time for AREA 2	20 Seconds
<b>P173E</b>	Entry Delay Time for AREA 3	20 Seconds
<b>P18E</b>	Exit Delay Time	60 Seconds
<b>P181E</b>	Exit Delay Time for AREA 1	60 Seconds
<b>P182E</b>	Exit Delay Time for AREA 2	60 Seconds
<b>P183E</b>	Exit Delay Time for AREA 3	60 Seconds
<b>P28E</b>	Siren Reset Time	10 Minutes

## ENTRY DELAY TIMERS

The Entry Delay Time is the time given to Disarm the panel after an Entry Delay zone is unsecured.

### P17E

This is the Global Entry Delay Time. Any value programmed at this option also changes all other Entry Delay Timers.

### P170E

This is the Entry Delay timer for zones assigned to more than one area. Any value programmed at this option also changes P17E. (*P171E, P172E, P173E are not affected*).

### P171E, P172E, P173E

Area 1, 2 and 3 Entry Delay times can be individually programmed with different values.

## EXIT DELAY TIME

The Exit Delay Time is the time given to vacate the premises after the panel is Armed. All zones except 24 hour zones are disabled during the Exit Delay Time.

### P18E

This is the Global Exit Delay Time. Any value programmed at this option also changes all other Exit Delay Timers. If different exit delays are required for each Area use P181E-P183E.

### P181E, P182E, P183E

Area 1, 2 and 3 Exit Delay Times can be individually programmed with different values.

## SIREN RESET TIME

The Siren Reset Time sets the duration of the Siren and Reset outputs.

Programmable from 1 – 99 minutes

# PROGRAMMING

SELECTION GROUP	OPTION No	DESCRIPTION	Zones																							
			1	2	3	4	5	6	7	8	9	10	11	12	13	14	15	16	17	18	19	20	21	22	23	24
SELECTION GROUP Only one option is selectable per zone	P19E	Security delay zones																								
	P20E	Instant zones			ON	ON	ON	ON	ON	ON	ON	ON	ON	ON	ON	ON	ON	ON	ON	ON	ON	ON	ON	ON	ON	ON
	P21E	Entry Delay zones	ON																							
	P22E	Handover zones		ON																						
	P23E	Secondary delay zones																								
SELECTION GROUP	P271E	Single trigger zones	ON	ON	ON	ON	ON	ON	ON	ON	ON	ON	ON	ON	ON	ON	ON	ON	ON	ON	ON	ON	ON	ON	ON	ON
	P272E	Double trigger zones																								

Factory default settings shown

## P19E – P272E

**PROGRAM MODE LEVEL:**  
Installer, Remote by PC

**FACTORY DEFAULT:**  
see table

**TO PROGRAM:**  
P [Option No] E [Zone No] E  
*Turns the option ON for each zone selected.*

**NOTES:**

- Selecting a zone attribute will turn off any other attribute within the same Selection Group.

**RELATED OPTIONS:**  
P441E Zones With No Exit Delay, page 26

## ZONE ASSIGNMENT

Each zone can be assigned with attributes which determine how the zone will be used.

### P19E

Security Delay can be assigned to zones already assigned to more than one Area, (Common Area Zones). When a Common Area Zone is assigned as a Security Delay Zone, the zone is Armed as soon as any Area it belongs to is Armed. (Unlike normal Common Area Zones, which are Armed only when *all* assigned Areas are Armed).

### P20E

Instant zones do not have Entry Delay.

### P21E

Entry Delay Zones operate only in the Armed state. These zones will activate the Entry Delay Timer (P17E) when they are triggered. If the panel is not Disarmed before the expiry of the Entry Delay Timer, the programmed alarm outputs will be activated.

### P22E

Handover zones are delayed only if entry is made through an Entry Delay zone first. If a Handover zone is triggered first, the zone behaves as an instant zone. Normally, the "point of entry" zone should be Delay zone, with any other zones in the entry path programmed as Handover zones.

### P23E

Secondary Delay Zones have an entry delay time equivalent to the Exit Delay Time (P18E).

### P271E

Single Trigger is the default for all zones. The zone alarms on each single trigger.

### P272E

Zones programmed to Double Trigger will recognise an alarm condition if:

- The Double Trigger zone has been triggered twice within a 4 minute period.
- If any 2 Double Trigger zones, each trigger once.
- A Double Trigger zone is left unsealed for longer than 15 seconds.

Double Trigger is suitable for zones with devices such as PIRs which self reset.



# PROGRAMMING

**SELECTION GROUP**  
Only one option is selectable per zone

OPTION No	TIME (milliseconds)	Zones																								
		1	2	3	4	5	6	7	8	9	10	11	12	13	14	15	16	17	18	19	20	21	22	23	24	
P251E	100																									
P252E	200																									
P253E	400																									
P254E	440 (Normal)	ON	ON	ON	ON	ON	ON	ON	ON	ON	ON	ON	ON	ON	ON	ON	ON	ON	ON	ON	ON	ON	ON	ON	ON	ON
P255E	480																									
P256E	520																									
P257E	560																									
P258E	600																									

Factory default settings shown

## P251E – P258E

**PROGRAM MODE LEVEL:**

Installer, Remote by PC

**FACTORY DEFAULT:**

P254E: All zones, Normal Sensitivity

**TO PROGRAM:**

P [Option No] E [Zone No] E

Turns the option ON for each zone selected.

## ZONE INPUT RESPONSE TIME

### P251E–P258E

The input response time can be adjusted for each zone. The factory default is 440ms. This option does NOT normally need to be adjusted.

This option is NOT related to Vibration Sensitivity.

Zones are allocated to one sensitivity level at any one time. Turning a zone ON in a sensitivity level, turns the zone OFF in any other sensitivity level.

**SELECTION GROUP**  
Only one option is selectable per zone

OPTION No	PULSES within 600ms	Zones																								
		1	2	3	4	5	6	7	8	9	10	11	12	13	14	15	16	17	18	19	20	21	22	23	24	
P261E	1 HIGHEST SENSITIVITY																									
P262E	2																									
P263E	3																									
P264E	5																									
P265E	10																									
P266E	15																									
P267E	20																									
P268E	25 LOWEST SENSITIVITY																									

Factory default settings shown

## P261E – P268E

**PROGRAM MODE LEVEL:**

Installer, Remote by PC

**FACTORY DEFAULT:**

no zones selected

**TO PROGRAM:**

P [26x] E [Zone No] E

Turns the option ON for each zone selected.

**NOTES:**

- Zones are allocated to one sensitivity level at any one time. Turning a zone ON in a sensitivity level, turns the zone OFF in any other sensitivity level.

**USING NESSSENSORS.**

Nessensors are sensitive to high frequencies and insensitive to low frequencies. Therefore it is not necessary to apply much force to the protected structure, rather a very rapid succession of blows.

The sensitivity has been correctly adjusted when a single blow applied with a soft object (e.g. by hand) does not cause an alarm whereas a rapid series of blows (using a metal object such as a screwdriver blade) will cause an alarm.

## VIBRATION SENSITIVITY

### P261E–P268E

Each zone has individually adjustable sensitivity for connection of Nessensor Vibration Sensors. Vibration Sensitivity counts pulses at 20ms intervals for a time window of 600ms.

There are 8 levels of vibration sensitivity. P261E is the most sensitive setting. P268E is the least sensitive setting. (Avoid using highest and lowest sensitivity – they are provided as a guide to the upper and lower limits).

**ADJUSTMENT**  
In addition to zone sensitivity adjustment, the overall sensitivity of the Nessensor can be adjusted by rotating the body of the Nessensor within its bracket.  
**The bracket must always be mounted horizontally and the arrow must point up for the required setting.**

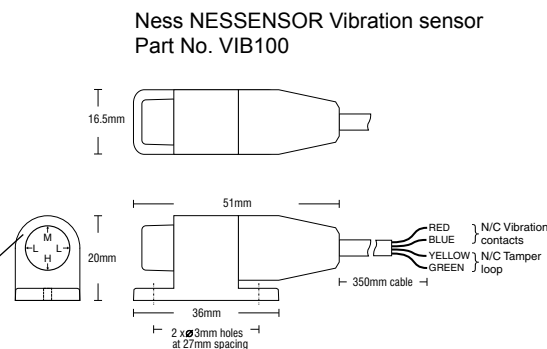

For efficient operation, Nessensors must be attached to fixtures using screws, *not* adhesive tape or silicone.

# PROGRAMMING

OPTION No	DESCRIPTION	Zones																							
		1	2	3	4	5	6	7	8	9	10	11	12	13	14	15	16	17	18	19	20	21	22	23	24
<b>P291E</b>	Siren Lockout ZONES	ON	ON	ON	ON	ON	ON	ON	ON	ON	ON	ON	ON	ON	ON	ON	ON	ON	ON	ON	ON	ON	ON	ON	ON
<b>P301E</b>	Excludable ZONES	ON	ON	ON	ON	ON	ON	ON	ON	ON	ON	ON	ON	ON	ON	ON	ON	ON	ON	ON	ON	ON	ON	ON	ON

TAMPER ALARMS		P292E Lockout	P302E Excludable
External Tamper	<b>1E</b>	ON	ON
Control Panel Tamper	<b>2E</b>	ON	ON
Zone input Tamper	<b>3E</b>	ON	ON
Radio Interface Tamper	<b>5E</b>	ON	ON

SYSTEM ALARMS		P293E Lockout	P303E Excludable
Keyswitch Panic	<b>1E</b>		ON
Dialler line fault	<b>2E</b>		ON
Keypad connection fault	<b>3E</b>		ON
Control Panel fault	<b>4E</b>		ON
Duress alarm	<b>5E</b>		ON
Panic alarm	<b>6E</b>		ON
Medical alarm	<b>7E</b>		ON
User Code alarm	<b>8E</b>		ON
Radio Supervision Alarm	<b>9E</b>		ON
RK4 Radio Key AUX button	<b>0E</b>		ON

POWER ALARMS		P294E Lockout	P304E Excludable
Mains power failure	<b>1E</b>		ON
Backup Battery low	<b>2E</b>		ON
DC supply failed	<b>3E</b>		ON
Zone reference supply failed	<b>4E</b>		ON
Radio Device battery low	<b>9E</b>		ON
Radio Key battery low	<b>0E</b>		ON

Factory default settings shown

## P29xE

**PROGRAM MODE LEVEL:**

Installer, Remote by PC

**FACTORY DEFAULT:**

see table

**TO PROGRAM:**

P [29x] E [Zone No] E

Toggles the option ON and OFF.

## SIREN LOCKOUT

Select the zones or alarms which will have Siren Lockout.

Siren Lockout zones/alarms will sound the Siren output once only during any Armed period but further alarms will trigger the Reset and Strobe output, (if programmed).

**P291E** Siren Lockout Zones

**P292E** Siren Lockout Tamper Alarms

**P293E** Siren Lockout System Alarms

**P294E** Siren Lockout Power Alarms

## P30xE

**PROGRAM MODE LEVEL:**

Installer, Remote by PC

**FACTORY DEFAULT:**

see table

**TO PROGRAM:**

P [30x] E [Alarm No] E

Toggles the option ON and OFF.

## EXCLUDABLE ALARMS

Select the zones or alarms which can be Excluded.

**P301E** Excludable Zones

**P302E** Excludable Tamper Alarms

**P303E** Excludable System Alarms

**P304E** Excludable Power Alarms

# PROGRAMMING

## AREA PARTITIONING

### DEFINITION

Area Partitioning allows the 24 zones to be split into 4 partitions; Areas 1, 2, 3 and Administrator (Admin) area.

By default, all zones are assigned to the Admin area. When there are no zones assigned to areas, a full Arm or Disarm turns the Admin area on and off.

### COMMON AREA ZONES

Zones assigned to more than one area are armed only when all the assigned areas are armed.

Common Area Zones will automatically Arm only when *all* the assigned areas are Armed. Common Area Zones will automatically Disarm when *any* of the assigned areas Disarms.

### OPERATION

Operation depends on the type of user code being used.

Area operation only applies to zones when they are in the armed state. This means that Day, 24hr and Monitor zones are independent of the area operations.

Note: Area partitioning is in addition and separate to Monitor Mode.

OPTION No	DESCRIPTION	Zones																							
		1	2	3	4	5	6	7	8	9	10	11	12	13	14	15	16	17	18	19	20	21	22	23	24
P310E	Assign zones to ADMIN AREA	ON	ON	ON	ON	ON	ON	ON	ON	ON	ON	ON	ON	ON	ON	ON	ON	ON	ON	ON	ON	ON	ON	ON	ON
P311E	Assign zones to AREA 1																								
P312E	Assign zones to AREA 2																								
P313E	Assign zones to AREA 3																								
P321E	Assign zones to MONITOR 1																								
P322E	Assign zones to MONITOR 2																								

Factory default settings shown

### P310E – P313E

#### PROGRAM MODE LEVEL:

Installer, Remote by PC

#### FACTORY DEFAULT:

All zones assigned to Admin area.

#### TO PROGRAM:

P [31x] E [Zone No] E \*

Toggles the option ON and OFF.

#### NOTES:

- If no Area operation is required, assign all zones to the Admin area (P310E).

### ASSIGNING ZONES TO AREAS

#### P310E Assign zones to Administrator area

When a zone is assigned to the Admin area it is automatically removed from all other areas.

\* P310E is used only to *add* zones to the Admin area. When a zone is assigned to any other area it is automatically removed from the Admin area.

#### P311E Assign or remove zones from Area 1

#### P312E Assign or remove zones from Area 2

#### P313E Assign or remove zones from Area 3

### P321E – P322E

#### PROGRAM MODE LEVEL:

Installer, Remote by PC

#### FACTORY DEFAULT:

No monitor zones.

#### TO PROGRAM:

P [32x] E [Zone No] E

Toggles the option ON and OFF.

#### NOTES:

### ASSIGNING MONITOR ZONES

Monitor mode allows partial arming of the system - eg., for night-time perimeter protection.

If also using Area Partitioning, assign Area 1 zones to Monitor 1 and Area 2 zones to Monitor 2.

#### P321E Assign zones to Monitor 1

#### P322E Assign zones to Monitor 2

## PROGRAMMING

OPTION No	DESCRIPTION		DEFAULT	
P33E	KEYPAD SHORTCUTS	1E	Two button keypad operation	
		2E	Shortcut ARMING	ON
		3E	Shortcut EXCLUDE	ON

### P33E, 1E-3E

**PROGRAM MODE LEVEL:**

Installer, Remote by PC

**FACTORY DEFAULT:**

Shortcut Arming & shortcut Exclude ON.

**TO PROGRAM:**

**P 33 E [Option] E**

*Toggles the option ON and OFF.*

**NOTES:**

### KEYPAD SHORTCUTS

These options will determine the keystrokes required to Arm, Monitor, Exclude, Panic, View.

**P33E 1E** Two button keypad operation

If this option is on, the ENTER button is also required for the above operations. E.g., Press ARM ENTER to Arm, MONITOR ENTER to Monitor, etc. Otherwise the keypad operation is single button.

**P33E 2E** Shortcut ARMING

If this option is on, a user code is not required to Arm.

**P33E 3E** Shortcut EXCLUDE

If this option is on, a user code is not required to Exclude.

**P33E SUMMARY**

1E OFF, 2E ON, 3E ON

Single button Arm/Monitor/Exclude

1E ON, 2E OFF, 3E ON

Arm/Monitor via code

1E ON, 2E ON, 3E OFF

Arm/Monitor/Exclude via code

or 2 button (Arm/Monitor/Exclude + E)

# PROGRAMMING

OPTION No	DESCRIPTION	DEFAULT	
<b>P34E</b>	MISC. SYSTEM OPTIONS	<b>1E</b> Keyswitch unrestricted operation	
		<b>2E</b> Chirp siren on K/S Arm/Disarm	
		<b>3E</b> Disable Auto-exclude	
		<b>4E</b> Entry beeps	ON
		<b>5E</b>	
		<b>6E</b> Disable zone tamper	ON
		<b>7E</b> Aux1 Armed output	
		<b>8E</b> Zone unsealed warning on Arming	

## P34E, 1E-8E

**PROGRAM MODE LEVEL:**

Installer, Remote by PC

**FACTORY DEFAULT:**

[see table]

**TO PROGRAM:**

**P 34 E [Option] E**

*Toggles the option ON and OFF.*

**NOTES:**

SIREN CHIRP: By default, the KEY input is a Panic input. **To use the KEY input as a keyswitch input, program P400E 1E**, (this maps the input to Output Group zero, which disables it as a zone).

**RELATED OPTIONS:**

P40xxE 1E: Mapping Keyswitch Panic (KEY input) to Output Groups, page 23.

### MISC. SYSTEM OPTIONS

**P34E 1E KEYSWITCH UNRESTRICTED OPERATION.**

OFF: A delay zone must be activated before operating the keyswitch otherwise an alarm will occur.

ON: The keyswitch operates at all times.

**P34E 2E CHIRP SIREN ON K/S ARM/DISARM.**

Selects Siren Chirp when Arming/Disarming by Keyswitch or Radio Key.

They KEY input must first be enabled as a keyswitch input

OFF: No siren chirp.

ON: Siren chirp on Arm/Disarm enabled.

**SIREN CHIRPS**

ARMING: One chirp from Siren B.

DISARM: Two chirps from Siren B.

**P34E 3E DISABLE AUTO-EXCLUDE.**

OFF: Auto-exclude is enabled. Zones unsealed at time of Arming are automatically excluded at the end of exit delay.

ON: Auto-exclude is disabled. Zones unsealed at time of Arming will activate the alarm at the end of exit delay.

**P34E 4E ENTRY BEEPS.**

OFF: No Entry Beeps.

ON: Keypad beeps during entry delay time.

**P34E 5E [not used]**

**P34E 6E DISABLE ZONE TAMPER.**

When Zone Tamper is enabled, the zones are sealed with two 4K7 resistors which allow monitoring of both Alarm and Tamper in each zone input over 4 wires. See page 7 for connection examples. Zone Tamper is disabled by default.

Zone Tamper looks for these resistances:

Zone Sealed: 2K2, Zone Alarm: 4K7, Tamper Alarm: Open circuit

OFF: Zone tamper enabled.

ON: Zone tamper disabled.

*Zone Tamper is available in D24 V1.2 and later.*

**P34E 7E AUX1 ARMED OUTPUT.**

OFF: Aux1 not affected by Arming.

ON: Aux1 follows panel Arm/Disarm state.

**P34E 8E ZONE UNSEALED WARNING ON ARMING.**

OFF: No zone unsealed warning.

ON: The RESET output will sound a 2 second alarm immediately on Arming if Arming with a zone unsealed.

# PROGRAMMING

OPTION No	PANEL STATE	Zones																								
		1	2	3	4	5	6	7	8	9	10	11	12	13	14	15	16	17	18	19	20	21	22	23	24	
P35xxE	ARMED																									
P36xxE	DISARMED																									
P37xxE	MONITOR MODE																									
P38xxE	24hr ZONES																									

Choose an Output Group (0-31)

Turn ON the zones required to be in the selected Output Group

### FACTORY DEFAULTS

Armed: P3517E - All zones selected on, (Output Group 17).  
 Disarmed: P360E - All zones selected on, (Output Group 0, disabled).  
 Monitor mode: P3720E - All zones selected on, (Output Group 20).  
 24hr zones: P380E - All zones selected on, (Output Group 0, disabled).

## P35xxE – P38xxE

**PROGRAM MODE LEVEL:**  
 Installer, Remote by PC

**FACTORY DEFAULT:**  
 [see table]

**TO PROGRAM:**  
**P** [Option No] **E** [Output Group] **E** [Zone] **E**  
*Maps zones to the selected output group.*

- NOTES:**
- Zones can be disabled by mapping them to Output Group 0.
  - Zones are removed from an output group by mapping them to a different output group.
  - Output Groups list, see page 24

**EXAMPLE 1:**  
 To make zones 23 & 24 into 24hr zones by mapping them to output group 17.

**P3817E 23E 24E**

**EXAMPLE 2:**  
 To map zones 1, 2 3 & 4 to output group 20 when Armed.

**P3520E 1E 2E 3E 4E**

## MAP ZONES TO OUTPUT GROUPS

These options set the output groups which any zone will trigger when alarmed. Zones can be setup to trigger a different output in each panel state.

### P35xxE ARMED

Map zones to output groups to be triggered when the panel is Armed.

**P35** [Output Group 0–31] **E** [Zone number] **E** [Zone number] **E** ...etc

Factory default setting is all zones mapped to output group 17. P3517E will show all 24 zones on.

### P36xxE DISARMED

Map zones to output groups to be triggered when the panel is Disarmed.

**P36** [Output Group 0–31] **E** [Zone number] **E** [Zone number] **E** ...etc

Factory default setting is all zones mapped to output group 0. P360E will show all 24 zones on. *This means that all zones are disabled when the panel is disarmed.*

### P37xxE MONITOR MODE

Assign zones to output groups to be triggered when the panel is in Monitor mode.

**P37** [Output Group 0–31] **E** [Zone number] **E** [Zone number] **E** ...etc

Factory default setting is all zones mapped to output group 20. P3720E will show all 24 zones on.

*To remove a zone from Monitor mode, assign it to Output Group P370E.*

### P38xxE 24HR ZONES

Create 24hr zones by mapping zones to output groups in this option.

**P38** [Output Group 0–31] **E** [Zone number] **E** [Zone number] **E** ...etc

Factory default setting is all zones mapped to output group 0. P380E will show all 24 zones on. *This means that no zones are 24hr zones.*

**Note: xx refers to the Output Group number. See the Output Groups table on page 24.**

# PROGRAMMING

OPTION No	DESCRIPTION		DEFAULT GROUP	
<b>P39xxE</b>	Map <b>TAMPER ALARMS</b> to output groups	1E	External Tamper	27
		2E	Control Panel Tamper	27
		3E	Zone input Tamper	27
		5E	Radio Interface Tamper	27
<b>P40xxE</b>	Map <b>SYSTEM ALARMS</b> to output groups	1E	Keyswitch Panic (KEY input)	22
		2E	Dialler line fault	24
		3E	Keypad connection fault	24
		4E	Control Panel fault	24
		5E	Duress alarm	29
		6E	Panic alarm	27
		7E	Medical alarm	30
		8E	User Code alarm	27
		9E	Radio Supervision Alarm	30
		0E	RK4 Radio Key Aux button	
<b>P41xxE</b>	Map <b>POWER ALARMS</b> to output groups	1E	Mains power failure	30
		2E	Backup Battery low	30
		3E	DC supply failed	23
		4E	Zone reference supply failed	23
		9E	Radio Device battery low	30
		0E	Radio Key battery low	30
<b>P42xxE</b>	Map <b>GENERAL PURPOSE TIMER</b> to output groups	1E	General Purpose Timer	0

Choose an Output Group (0-31)

Turn ON the alarms required to be in the selected Output Group

## P39xxE – P42xxE

**PROGRAM MODE LEVEL:**  
Installer, Remote by PC

**FACTORY DEFAULT:**  
[see table]

**TO PROGRAM:**  
P [Option No] E [Output Group] E [Alarm No] E  
*Maps alarms to the selected output group.*

- NOTES:**
- Alarms can be disabled by mapping them to Output Group 0.
  - Alarms are removed from an output group by mapping them to a different output group.
  - To use the KEY input as a keyswitch input, program P400E 1E, (this maps the input to Output Group zero, which disables it as a zone).

**EXAMPLE:**  
To make zones 23 & 24 into 24hr zones by mapping them to output group 17.

**P3817E 23E 24E**

## MAP ALARMS TO OUTPUT GROUPS

These options set the output groups which various system alarms will trigger when alarmed.

**P39xxE MAP TAMPER ALARMS**  
P39 [Output Group 0–31] E [Tamper Alarm number] E

**P40xxE MAP SYSTEM ALARMS**  
P40 [Output Group 0–31] E [System Alarm number] E

**P41xxE MAP POWER ALARMS**  
P41 [Output Group 0–31] E [Power Alarm number] E

**P42xxE MAP GENERAL PURPOSE TIMER**  
P42 [Output Group 0–31] E 1E

**Note:** xx refers to the Output Group number, (can be either one or two digits) See the Output Groups table on page 24.

# PROGRAMMING

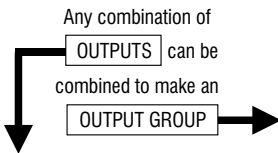

OUTPUT GROUPS Table

		OUTPUT GROUPS																															
		INSTALLER DEFINED															FACTORY DEFINED																
		0	1	2	3	4	5	6	7	8	9	10	11	12	13	14	15	16	17	18	19	20	21	22	23	24	25	26	27	28	29	30	31
<b>OUTPUTS</b>	1	SIREN A																	•				•	•				•	•				
	2	SIREN B																	•				•	•				•	•				
	3	RESET																	•				•	•				•	•				
	4	STROBE																	•				•	•				•	•				
	5	AUX 1																										•					
	6	AUX 2 (Relay)																								•							
	7	SONALERT																									•						
	8	FIRE																										•					
	9	SIREN A Burst																									•						
	10	RESET Burst																										•					
	11	PRE-ALARM Sonalert																				•	•										
	12	DIALLER																	•	•			•	•				•	•		•	•	
	13	TIMER																															
	14	ALARM STATE																	•	•	•	•	•	•	•		•	•	•	•			
	15	SIREN TONE 1																	•														
	16	SIREN TONE 2																					•	•				•	•				

Zones or alarms mapped to Output Group 0 will be disabled

MEDICAL

### WHAT ARE OUTPUT GROUPS?

Output Groups are different combinations of the 16 available outputs. Any type of alarm can be mapped to an Output Group.

The use of Output Groups simplifies the mapping of outputs to inputs.

For example, by mapping a zone to Output Group 17, the zone will trigger these outputs: SIREN A & SIREN B (Siren Tone 1), RESET, STROBE AND DIALLER.

Output Groups 1–15 are blank by default and can be defined by the installer.

Output Groups 16–31 are factory defined with commonly used combinations of outputs.

Any zone or alarm can be disabled by mapping it to Output Group 0.

### WHAT ARE OUTPUTS?

Outputs are physical or virtual outputs such as Siren outputs, the Strobe output, the Dialler etc.

### OUTPUTS, DEFINED

The D24 has 16 individual outputs which can be mapped, through Output Groups, to various alarms.

- SIREN A:** Siren driver output for connecting a maximum of 3 x 8 ohm horn speakers.
- SIREN B:** Second siren output with the same specifications as SIREN A.
- RESET:** 12V DC output for connecting Ness Sirens, piezo sirens, etc.
- STROBE:** Latched 12VDC output for connecting strobe lights.
- AUX 1:** The AUX output is a programmable Open Collector output suitable for LEDs, Relays, etc.
- AUX 2 RELAY:** Dry changeover contacts, (N.C. COM. N.O.) with a contact rating of 2A @ 24V.
- SONALERT:** Beeps all keypads when activated.
- FIRE:** Fire indicator icon on all keypads.
- SIREN A BURST:** Siren A output burst for 2 seconds.
- RESET BURST:** Reset output burst for 1 second.
- Pre-Alarm Sonalert:**
  - Sonalert beeps on all keypads when an input turns on.
  - Pre-alarm time is equal to entry delay. Siren A bursts at the end of Pre-Alarm if panel reset has not cancelled it.
  - The sonalert is turned off upon panel reset.
- DIALLER:** Reports alarms by dialler when the mapped input alarms.
- TIMER:** Programmable general purpose timer
- ALARM STATE:**
  - If selected, alarm indicators fast flash when any input assigned to the output turns on. The alarm clears only when the panel is reset by entering a code.
  - If not selected, outputs follow the inputs and alarm indicators turn on steady when the input is on.
- SIREN TONE 1:**
- SIREN TONE 2:**



# PROGRAMMING

			OUTPUT GROUPS															
			INSTALLER DEFINED															
Method 1	Method 2	Output	1	2	3	4	5	6	7	8	9	10	11	12	13	14	15	
P43xxE	1E	1E	1	SIREN A														
	2E	2E	2	SIREN B														
	3E	P80xxE	3E	3	RESET													
	4E		4E	4	STROBE													
	5E		5E	5	AUX 1													
	6E		6E	6	AUX 2 (Relay)													
	7E		7E	7	SONALERT													
	8E		8E	8	FIRE													
	9E	9E	9	SIREN A Burst														
	10E	10E	10	RESET Burst														
11E	P81xxE	1E	11	PRE-ALARM Sonalert														
12E		2E	12	DIALLER														
13E		3E	13	TIMER														
14E		4E	14	ALARM STATE														
15E		5E	15	SIREN TONE 1														
16E		6E	16	SIREN TONE 2														

## P43xxE

**PROGRAM MODE LEVEL:**

Installer, Remote by PC

**FACTORY DEFAULT:**

[see table]

**TO PROGRAM:**

**P43** [Output Group 1–15] **E** [Output 1–16] **E**  
*Maps alarms to the selected output group.*

**NOTES:**

- This method does not provide visual feedback when programming.

## CREATING INSTALLER-DEFINED OUTPUT GROUPS

### METHOD 1

There are two methods for building your own Output Groups.

Method 1 uses the option **P43uuE yyE, yyE...etc** to add outputs when building Output Groups 1–15.

**uu** = Output Group 1–15, **yy** = Output 1–16 (select 1E–16E)

This method should only be used by experienced installers as it provides no visual feedback when programming.

**TO PROGRAM:**

**P43** [Select an Output Group 1–15] **E** [Select outputs 1–16] **E ...**

**EXAMPLE:**

To build Output Group 1 to include the outputs: Output 1: Siren A, Output 3: Reset, Output 12: Dialler

**P43 1E 1E 3E 12E**

## P80xxE, P81xxE

**PROGRAM MODE LEVEL:**

Installer, Remote by PC

**FACTORY DEFAULT:**

[see table]

**TO PROGRAM:**

**P80** [Output Group 1–15] **E** [Output 1–10] **E**  
**P81** [Output Group 1–15] **E** [Output 9–16] **E**  
*Maps alarms to the selected output group.*

**NOTES:**

- This method provides visual feedback when programming.

### METHOD 2

Method 2 provides a visual display of the outputs added to the selected Output Group but uses 2 separate program options to add the 16 possible outputs to an Output Group.

**P80 uuE yyE**

**uu** = Output Group 1–15, **yy** = Output 1–10 (select 1E–10E)

**P81 uuE yyE**

**uu** = Output Group 1–15, **yy** = Output 11–16 (select 1E–6E)

**TO PROGRAM:**

**P80** [Select an Output Group 1–15] **E** [Select outputs 1–10] **E ...**

**P81** [Select an Output Group 1–15] **E** [Select outputs 9–16] **E ...**

**EXAMPLE:**

To build Output Group 1 to include the outputs: Siren A (Output 1), Reset (Output 3), Dialler (Output 12).

**P80 1E 1E 3E P81 1E 2E**

## DIALLER - PROGRAMMING

OPTION No	DESCRIPTION	Zones																								
		1	2	3	4	5	6	7	8	9	10	11	12	13	14	15	16	17	18	19	20	21	22	23	24	
P441E	Zones with no Exit Delay																									

Factory default settings shown

### P441E

**PROGRAM MODE LEVEL:**

Installer, Remote by PC

**FACTORY DEFAULT:**

no zones selected

**TO PROGRAM:**

P441E [Zone No] E

Turns the option ON or OFF for each zone.

**RELATED OPTIONS:**

P19E Security Delay, page 16

### ZONES WITH NO EXIT DELAY

Select the zones which will not have exit delay. Normally, all zones are delayed during exit delay allowing the user to leave the premises through any zone/s.

**TO PROGRAM:**

P 441 E [Select zone] E ...

**EXAMPLE:**

To program zones 8, 9 & 10 to have no exit delay:

P441E 8E 9E 10E

OPTION No	DESCRIPTION		DEFAULT
P45E	TEST OPTIONS	1E	Installation walk test mode
		2E	Enable Auto Zone Test

### P45E 1E, 2E

**PROGRAM MODE LEVEL:**

Installer, Remote by PC

**FACTORY DEFAULT:**

see table

**TO PROGRAM:**

P45E [Select option] E.

**NOTES:**

- Zone icons during P45E 1E test.

OFF: zone not selected for test

ON: zone not triggered

FAST FLASH: zone triggered

### TEST OPTIONS

**P45E 1E INSTALLATION WALK TEST MODE.**

This test runs in installer program mode while P45E 1E is selected. Outside of installer program mode, the test is suspended but the zone selection remains.

ON: Installation Walk Test Mode is enabled.

To enter test mode, press **P45E 1E** The  icon will fast flash, then press **[zone number] E, [zone number] E...** etc. Select (or de-select) the zones to test. As each zone is selected, the corresponding zone icon will turn on.

Each test zone will now, on going unsealed, cause it's zone indicator to fast flash and the Reset output to give a 2 second burst.

To cancel the walk test press the **E** button.

To restart the walk test, press **1E**, The  icon will resume flashing. The previously selected test zones will be on.

**P45E 2E AUTOMATIC ZONE TEST.**

This test can identify potentially faulty detection devices by alerting the user to zones which have not unsealed during the past 20 Arm and Disarm cycles.

If selected, the test runs during the normal operation of the panel.

If any non-24hr zone/s does not unseal during 20 Arming cycles, the D24 will alert the user by turning on the  icon.

You can view the offending Zone(s) by pressing **VIEW 7**. The offending zone(s) icons will be ON.

To clear the Zone Test label, unseal the offending zone(s) while still in the **VIEW 7** mode. This will result in the steady zone icon changing to a fast flash. This will verify whether the zone is functioning correctly or not.

To cancel the display press the **E** button.

If the  icon remains on, press **VIEW 7** then **E**.

**CAUTION:**

Automatic Zone Test is often used to identify inactive zones on a system where regular zone activity is expected.

Automatic Zone Test will obviously alert you to zones which remain sealed for extended periods. (For example, manhole cover reed switch).

## DIALLER - PROGRAMMING

OPTION No	DESCRIPTION	DEFAULT
P50E	Client Code	
P51E	Telephone Number 1 - Primary	
P52E	Telephone Number 2 - Secondary	
P53E	Telephone Number 3 - Callback	

### P50E

#### PROGRAM MODE LEVEL:

Installer, Remote by PC

#### FACTORY DEFAULT:

0000

#### TO PROGRAM:

P 50E [Client Code] E

#### RELATED OPTIONS:

P75xE Client Codes for Areas

### CLIENT CODE

The client code is a 4 digit decimal number which identifies the panel to the central station.

#### HEX ACCOUNT NUMBER

If the Client Account Number is required to be sent in Hex, use this table when programming.

(Hex A cannot be used).

#### HEX DIGIT

B  
C  
D  
E  
F

#### Keypad KEY

VIEW  
ARM  
MONITOR  
AREA  
EXCLUDE

#### Keypad Display

11  
12  
13  
14  
15

### P51E, P52E, P53E

#### PROGRAM MODE LEVEL:

Installer, Remote by PC

#### FACTORY DEFAULT:

none

#### TO PROGRAM:

P [5xE] [Telephone number] E

#### NOTES:

The telephone numbers, (including special characters), can be up to 18 digits long.

### P51E TELEPHONE NUMBER 1

The primary telephone number for reporting alarms to the central station.

### P52E TELEPHONE NUMBER 2

The secondary telephone number for reporting alarms to the central station.

### P53E TELEPHONE NUMBER 3 - CALLBACK

The callback telephone number is used by the panel when doing an upload/download callback.

### SPECIAL CHARACTERS FOR TELEPHONE NUMBERS

#### SPECIAL CHARACTERS (Applies to all telephone Numbers)

Pauses, \* (star) or # (hash) (VF digits) can be included in the dialling sequence by using the keys in the table below.

SPECIAL CHARACTER	KEY ENTRY	INDICATION ON LCD DISPLAY
PAUSE (1.6sec)	AREA Key	6 (Flashing)
* (Star)	ARM Key	2 (Flashing)
# (Hash)	MONITOR Key	3 (Flashing)

### PROGRAMMING FEEDBACK

When programming client codes and telephone numbers, the existing digits and then the new digits are 'read back' by flashing the numeric keypad icons 0-9.

1. Press: **P [Option No] E** the existing client code or phone number is displayed by the keypad.
2. Enter the new client code or phone number: **[New number] E** the new number will be displayed.

*NOTE: After step 1, the new number can be entered immediately without waiting for the display to finish the 'read back'.*

**DIALLER - PROGRAMMING**

OPTION No	DESCRIPTION		DEFAULT
P54E	REPORTING FORMAT	1E	
		2E	Audible Voice format
		3E	Contact ID
			ON

**P54E****PROGRAM MODE LEVEL:**

Installer, Remote by PC

**FACTORY DEFAULT:**

Contact ID format

**TO PROGRAM:**

P54E [Select option] E

**REPORTING FORMAT****P54E 2E AUDIBLE VOICE FORMAT**

Audible Voice format for reporting alarms to any telephone or mobile phone. The audible voice message repeats the word "ALARM".

The person receiving the call can then acknowledge the alarm by pressing the **#** key on their telephone. Press the **#** key for at least 2 seconds during pauses in the audible message.

*Open/Close reports and Excluded Zone reports are automatically disabled when Audible Format is enabled.*

*Audible Voice format is available in D24 V1.5 and later.*

**P54E 3E CONTACT ID FORMAT**

Contact ID format is used for reporting alarms to the central station.

**See page 58 for the full list of Contact ID reporting codes.**

## DIALLER - PROGRAMMING

OPTION No	DESCRIPTION		DEFAULT	
P55E	DIALLING FORMAT	1E	Auto dialling, PULSE or DTMF	ON
		2E	PULSE dialling always	
		3E	DTMF dialling always	
P57E	ALTERNATE DIALLING	1E	Alternate dialling Pri/Sec numbers	ON
		2E	Dial each phone number 5 times	
		3E	Repeat to phone No 2	

### P55E

**PROGRAM MODE LEVEL:**

Installer, Remote by PC

**FACTORY DEFAULT:**

Auto dialling

**TO PROGRAM:**

P55E [Select option] E

### DIALLING FORMAT

The D24 will dial in either DTMF or Pulse depending on the type of dial tone sensed. In some instances it may be necessary to dial in a particular format regardless of the dial tone.

**P55E 1E AUTO DIALLING**

Dials in DTMF or Pulse depending on the type of dial tone sensed. When this option is selected, the panel will make the first dialling attempt in DTMF and the remaining attempts in Pulse dialling. This is to prevent false DTMF dial tones from disabling the dialler.

**P55E 2E PULSE DIALLING ALWAYS**

Always dials in Pulse (Decadic) format.

**P55E 3E DTMF DIALLING ALWAYS**

Always dials in DTMF (Tone) format.

### P57E

**PROGRAM MODE LEVEL:**

Installer, Remote by PC

**FACTORY DEFAULT:**

Alternate dialling

**TO PROGRAM:**

P57E [Select option] E

### ALTERNATE DIALLING

**P57E 1E ALTERNATE DIALLING PRI/SEC NUMBERS**

Alternate dialling between the Primary and Secondary telephone numbers, until successful.

Alternate dialling between the Primary and Secondary telephone numbers, until successful, occurs for the maximum number of 20 dial out attempts. This consists of 2 rounds of 10 calls, ( 5 per number) including a sleep time of 5 minutes between attempts.

**P57E 2E DIAL EACH PHONE NUMBER 5 TIMES**

Dial the Primary telephone number 5 times. If unsuccessful, dial the Secondary telephone number 5 times.

**P57E 3E REPEAT TO PHONE NO 2**

Report to the Primary telephone number and repeat to the Secondary telephone number.

**DIALLER - PROGRAMMING**

OPTION No	DESCRIPTION		DEFAULT	
<b>P58E</b>	REMOTE ACCESS OPTIONS	1E	Enable upload/download with Callback	
		2E	Enable upload/download with Fax Defeat	
		3E	Enable remote ADMIN Arming	
		4E	Enable remote AREA 1 Arming	
		5E	Enable remote AREA 2 Arming	
		6E	Enable remote AREA 3 Arming	
		7E	Enable remote toggle AUX1 & AUX2	
		8E	Enable remote Disarm all Areas	
<b>P59E</b>	Required Rings to Auto-answer		1	
<b>P60E</b>	OPEN/CLOSE REPORTING OPTIONS	1E	Enable Open/Close reports	ON
		2E	Send only ADMIN AREA O/C reports	
		3E	Send O/C reports with Client codes as per P75xxE	
		4E	Disable Open/Close reports	

**P58E**

**PROGRAM MODE LEVEL:**  
Installer, Remote by PC

**FACTORY DEFAULT:**  
none

**TO PROGRAM:**  
**P58E** [Select option] E

**REMOTE ACCESS OPTIONS**

These options will enable the D24 to auto answer an incoming call and carry out the functions as described.

See REMOTE OPERATION BY TELEPHONE, page 51.

**P59E**

**PROGRAM MODE LEVEL:**  
Installer, Remote by PC

**FACTORY DEFAULT:**  
1 ring

**TO PROGRAM:**  
**P59E** [required rings] E (Select 0 to 20 rings)

**REQUIRED RINGS TO AUTO-ANSWER**

This option sets the number of double rings before the D24 enables auto-answering of the next call.

The number of rings can be set from 0 to 20 rings. 1 ring is recommended for fax defeat to work correctly.

**FAX DEFEAT**

Fax Defeat works as follows:

1. Phone the D24 telephone number and listen for the required number of rings (ring ring...ring ring) and then hang up.
2. Call the number again within 60 seconds.
3. The dialler will answer the very next incoming call on the first ring detected (this may require one or two rings in practice).

If 60 seconds has expired before the next call, the dialler will revert back to the count-ring mode as above.

**P60E**

**PROGRAM MODE LEVEL:**  
Installer, Remote by PC

**FACTORY DEFAULT:**  
1E on: Open/Close reports enabled

**TO PROGRAM:**  
**P60E** [Select option] E

**OPEN/CLOSE REPORTING OPTIONS**

**P60E 1E ENABLE OPEN/CLOSE REPORTS**

**P60E 2E SEND ONLY ADMIN AREA OPEN/CLOSE REPORTS**

**P60E 3E SEND O/C REPORTS WITH CLIENT CODES AS PER P75XXE**

This option enables the reporting of Area open/close reports using the Client numbers as programmed at options P751E, P752E, P753E.

**P60E 4E DISABLE OPEN/CLOSE REPORTS**

When this option is enabled, option 1E automatically disables.

If Open/Close reports are disabled, the panel will send a FORCED OPENING REPORT if there has been an alarm during the armed period.

## DIALLER - PROGRAMMING

OPTION No	DESCRIPTION	ZONE	DEFAULT CHANNEL	ZONE	DEFAULT CHANNEL	ZONE	DEFAULT CHANNEL
<b>P61E</b>	Map <b>ZONE ALARMS</b> to Contact ID channels	1	130	9	130	17	130
		2	130	10	130	18	130
		3	130	11	130	19	130
		4	130	12	130	20	130
		5	130	13	130	21	130
		6	130	14	130	22	130
		7	130	15	130	23	130
		8	130	16	130	24	130

OPTION No	DESCRIPTION	DEFAULT CHANNEL		
<b>P62E</b>	Map <b>TAMPER ALARMS</b> to Contact ID channels	1E	External Tamper	137
		2E	Control Panel Tamper	137
		3E	Zone input Tamper	144
		5E	Radio Interface Tamper	383

<b>P63E</b>	Map <b>SYSTEM ALARMS</b> to Contact ID channels	1E	Keyswitch Panic	120
		2E	Dialler line fault	350
		3E	Keypad connection fault	307
		4E	Control Panel fault	307
		5E	Duress alarm	121
		6E	Panic alarm	120
		7E	Medical alarm	100
		8E	User Code alarm	137
		9E	Radio Supervision Alarm	306
		0E	RK4 Radio Key AUX button	

<b>P64E</b>	Map <b>POWER ALARMS</b> to Contact ID channels	1E	Mains power failure	301
		2E	Backup Battery low	309
		3E	DC supply failed	307
		4E	Zone reference supply failed	307
		9E	Radio Device battery low	384
		0E	Radio Key battery low	384

### P61E–P64E

#### PROGRAM MODE LEVEL:

Installer, Remote by PC

#### FACTORY DEFAULT:

see tables

#### TO PROGRAM:

**P61E** [Select zone] E [Select code] E

**P62E** [Select alarm no] E [Select code] E

**P63E** [Select alarm no] E [Select code] E

**P64E** [Select alarm no] E [Select code] E

### MAPPING CONTACT ID CHANNELS

All alarm types report a preset Contact ID code to the central station. These codes do not normally need to be changed.

#### EXAMPLE

To program zone 12 to report it's alarms on Contact ID channel 120.

**P61E 12E 120E**

To disable a zone or other alarm from reporting, enter zero as the reporting channel.

**P6xE [alarm/zone number] E 0E**

See page 58 for the full list of Contact ID reporting codes.

## DIALLER - PROGRAMMING

OPTION No	DESCRIPTION		DEFAULT	
P65E	MULTIPLE ALARM REPORTING	1E	Disable reporting multiple zone alarms	ON
		2E	Enable reporting multiple zone alarms	
P66E	RESTORALS REPORTING	1E	Send Restorals after Siren Time	
		2E	Send Restorals on Disarm	
		3E	Send Restorals immediately	ON
		4E	Do not send Restorals	

### P65E

**PROGRAM MODE LEVEL:**

Installer, Remote by PC

**FACTORY DEFAULT:**

Multiple reporting disabled

**TO PROGRAM:**
**P65E 1E** to disable multiple alarm reporting

**P65E 2E** to enable multiple alarm reporting

### MULTIPLE ALARM REPORTING

By default, the panel will report zone alarms once per arming cycle.

P65E 1E and 2E will toggle the selection of 'single hit' and 'multibreak' reporting.

### P66E

**PROGRAM MODE LEVEL:**

Installer, Remote by PC

**FACTORY DEFAULT:**

3E on: Restorals sent immediately

**TO PROGRAM:**
**P66E** [Select option] E

### RESTORALS REPORTING

These options apply only to zone alarms.

All other alarm types send Restorals when they happen, except for Duress, Panic, Access Code and Medical for which a Restoral is never sent.

**P66E 1E SEND RESTORALS AFTER SIREN TIME**

The Restoral is sent when Siren Time (P28E) has expired and the input has resealed.

**P66E 2E SEND RESTORALS ON DISARM**

The Restoral is sent when the panel is next Disarmed, provided the input has resealed.

**P66E 3E SEND RESTORALS IMMEDIATELY**

The Restoral is sent immediately the input has resealed.

**P66E 4E DO NOT SEND RESTORALS**

This option disables the reporting of zone Restorals.

OPTION No	DESCRIPTION	DEFAULT
P67E	Mains Fail reporting delay	60 minutes

### P67E

**PROGRAM MODE LEVEL:**

Installer, Remote by PC

**FACTORY DEFAULT:**

60 minutes

**TO PROGRAM:**
**P67E** [time] E (Select 0–255 minutes)

**RELATED OPTIONS:**

P41E xxE, Mapping power alarms, page 23

### MAINS FAIL REPORTING DELAY

This option sets the time, in minutes, for reporting of Mains power failure to be delayed. This prevents the unnecessary reporting of brief power interruptions.

The delay time can be programmed from 0–255 minutes.

Mains Power Failure is enabled and configured as an alarm by the related option P41xxE 1E.



## DIALLER - PROGRAMMING

OPTION No	DESCRIPTION	DEFAULT
P68E	Zone reporting Abort Delay	30 seconds

OPTION No	DESCRIPTION	Zones																							
		1	2	3	4	5	6	7	8	9	10	11	12	13	14	15	16	17	18	19	20	21	22	23	24
P69E	Abort Delay Zones																								

### P68E, P69E

**PROGRAM MODE LEVEL:**  
Installer, Remote by PC

**FACTORY DEFAULT:**  
P68E: 30 seconds  
P69E: no zones

**TO PROGRAM:**  
P68E [time] E  
(Enter 0–100 seconds or 101–220 for 1–120 minutes)  
P69E [zone] E [zone] E ... etc

### ZONE REPORTING ABORT DELAY

Any zone can be programmed for abort operation which means the zone must remain unsealed for the specified time before it is recognised as an alarm.

**P68E ABORT DELAY TIME.**  
There are two time ranges.  
Enter a value of 0–100 for 0–100 seconds.  
Enter a value of 101–220 for 1 to 120 minutes.

**P69E ABORT DELAY ZONES**  
Selects the zones which will have Abort Delay Time.  
Press P69E zone number E zone number E... etc up to 24 zones.

OPTION No	DESCRIPTION	DEFAULT
P70E	Time before first test call	168 hours
P71E	Test call interval	0 (disabled)

### P70E, P71E

**PROGRAM MODE LEVEL:**  
Installer, Remote by PC

**FACTORY DEFAULT:**  
Time before first test call: 168 hours  
Test call interval: 0 (disabled)

**TO PROGRAM:**  
P70E [time] E (0–255 hours)  
P71E [time] E (0–255 hours)

DAYS	HOURS
1	24
2	48
3	72
4	96
5	120
6	144
7	168
8	192
9	216
10	240

### TEST CALLS

The D24 can be programmed to send periodic test calls to the Central Station.

**P70E TIME BEFORE FIRST TEST CALL.**  
This option is used to set the preferred time for Test Calls. Programmable from 0–255 hours. Enter a value between 0 and 255.

**Examples:**  
**A/ New Installation:** Set the time before the first test call.  
E.g., If you are programming the panel at 5pm and you want test calls to be sent at 1am. Enter P70E 8E (5pm + 8hrs = 1am).

**B/ Existing Installation:** To reset the time that test calls are sent.  
E.g., Our example panel is sending test calls at 1am and you want to change it to 2am. If you are programming the panel at 3pm, enter P70E 11E (3pm + 11hrs = 2am).

**P71E TEST CALL INTERVAL.**  
Sets the time between test calls. Commonly set for 168 hours, (7 days), (ask your central station).

Programmable from 0–255 hours. Enter a value between 0 and 255.

A value of 0 (zero) disables test calls (factory default).

**Test Call times commence on exit from installer program mode.**

## DIALLER - PROGRAMMING

OPTION No	DESCRIPTION	DEFAULT
P72E	Enable Easycall feature	1E OFF
P73E	Digits to dial after Opening	0 (disabled)
P74E	Digits to dial after Closing	0 (disabled)

### P72E, P73E, P74E

**PROGRAM MODE LEVEL:**

Installer, Remote by PC

**FACTORY DEFAULT:**

Easycall disabled

**TO PROGRAM:**

P72E 1E toggles the option ON and OFF

P73E [digits] E (Up to 15 digits to dial)

P74E [digits] E (Up to 15 digits to dial)

**NOTES:**

The digits programmed at P73E and P74E are not dependant on Open/Close reports. If Open/Close reports are disabled, the digits will be dialled after Arming/Disarming.

### EASYCALL DIALLING

The D24 can dial pre-programmed digits after opening and closing reports. This can be used to automatically enable and disable Easycall telephone diversion of the premises telephone every time the panel is Armed and Disarmed.

**P72E ENABLE EASYCALL FEATURE**

Press P72E 1E to enable/disable the option. The option is off by default.

**P73E DIGITS TO DIAL AFTER OPENING**

Press P73E [digits] E

Normally, you would want to disable Easycall diversion after opening, ie., the client is now at home.

Example: (P) (7) (3) (E) (MONITOR) (2) (1) (MONITOR) (E)

The digits #21# will be dialled after the panel has sent the Opening Report (if enabled).

**P74E DIGITS TO DIAL AFTER CLOSING**

Press P74E [digits] E

Program the telephone number to divert to.

Example:

(P) (7) (4) (E) (ARM) (2) (1) [telephone number] (MONITOR) (E)

The digits \*21 [telephone number] # will be dialled after the panel has sent the Closing Report (if enabled).

### SPECIAL CHARACTERS FOR TELEPHONE NUMBERS

**SPECIAL CHARACTERS (Applies to all telephone Numbers)**

Pauses, \* (star) or # (hash) (VF digits) can be included in the dialling sequence by using the keys in the table below.

SPECIAL CHARACTER	KEY ENTRY	INDICATION ON LCD DISPLAY
PAUSE (1.6sec)	AREA Key	6 (Flashing)
* (Star)	ARM Key	2 (Flashing)
# (Hash)	MONITOR Key	3 (Flashing)

## DIALLER - PROGRAMMING

OPTION No	DESCRIPTION	DEFAULT
<b>P750E</b>	ADMIN Area client code	0000
<b>P751E</b>	AREA 1client code	0000
<b>P752E</b>	AREA 2client code	0000
<b>P753E</b>	AREA 3client code	0000

### P750E–P753E

**PROGRAM MODE LEVEL:**  
Installer, Remote by PC

**FACTORY DEFAULT:**  
0000

**TO PROGRAM:**  
P [75x] E [Client Code] E

**RELATED OPTIONS:**  
P60E 3E, Send Open/Close with Client Codes as per P75xE

### AREA CLIENT CODES

These options are for programming individual client codes for each Area. Option P60E 3E must also be on.

**P750E** Admin Area client code. **P751E** Area 1 client code. **P752E** Area 2 client code. **P753E** Area 3 client code.

HEX ACCOUNT NUMBER If the Client Account Numbers are required to be sent in Hex, use this table when programming. (Hex A cannot be used).	HEX DIGIT	Keypad KEY	Keypad Display
	B	VIEW	11
	C	ARM	12
	D	MONITOR	13
	E	AREA	14
	F	EXCLUDE	15

### P80E, P81E

### CREATE INSTALLER DEFINED OUTPUT GROUPS - METHOD 2

See page 25

OPTION No	DESCRIPTION	DEFAULT
<b>P82E</b>	<b>1E</b> [not used]	
	<b>2E</b> Enable Dialler	ON
	<b>3E</b> Enable Radio Interface	
	<b>4E</b> Enable Output Expander	

### P82E

**PROGRAM MODE LEVEL:**  
Installer, Remote by PC

**FACTORY DEFAULT:**  
2E on: Dialler enabled  
3E off: Radio Interface disabled  
4E off: Output Expander disabled

**TO PROGRAM:**  
P82E [Select option] E

### ENABLE OPTIONS

**P82E 1E:**  
Not used

#### **P82E 2E: ENABLE THE DIALLER.**

(On by default). This option can be used to disable the dialler while retaining all dialler programming.

#### **P82E 3E: ENABLE RADIO INTERFACE.**

(Off by default).

Enables the optional 100-200 Radio Interface, (if used).

#### **P82E 4E: ENABLE OUTPUT EXPANDER.**

(Off by default).

Enables the optional 100-011 Output Expander, (if used).

The optional D24 Output Expander connects to the D24 control panel and provides 35 open collector outputs and 1 relay output.

The outputs can be used to drive mimic displays, provide additional outputs on alarm and various other custom purposes.

The Output Expander board interfaces with the D24 by three wire serial connection. The board is designed to fit inside the D24 control panel housing.

**For full details of Output Expander operation, see page 52.**

# NESS RADIO

## NOTES:

- The Ness Radio Interface is normally installed inside the control panel box.
- In cases where the receiver needs to be located closer to the transmitters, the Ness Radio Interface can be installed up to 50 metres away from the control panel. Use 14/0.20 shielded cable or equivalent. The shield can either be connected to the EARTH connection or left unconnected. Leave the shield unconnected at the receiver end.
- If the Radio Interface is installed inside a metal enclosure, the antenna wire should protrude outside the enclosure.
- For best performance, the antenna wire should be kept straight and not coiled, shortened or extended.
- The optional 100-046 Whip Antenna can be used in cases where radio reception is marginal. The whip antenna may not improve reception in all cases, however its reception pattern may better suit the local radio environment.

## NESS RADIO INTERFACE

The Ness Radio Interface (100-200) is the optional radio receiver required to enable all radio functions.

Connection to the control panel is via a 4 wire loom and plug supplied with the Ness Radio Interface.

### NESS D24 CONTROL PANEL J3 CONNECTOR

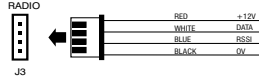

### NESS RADIO INTERFACE

Part No. 100-200



NESS RADIO DEVICES  
Radio Events Table



SIGNAL TYPE	RKP RADIO KEYPAD 100-001	RK1 RADIO KEY PENDANT 100-683	RK3 RADIO KEY 3 BUTTON 100-664	RK4 RADIO KEY 4 BUTTON 100-067	R12 RADIO PIR R15 RADIO PIR 100-691/100-663	RR1/RR2 RADIO REED SWITCH 100-662/100-527	RPB RADIO EMERG BUTTON 100-283	RSM RADIO SMOKE DETECTOR 106-040
ARM / DISARM	15 User IDs		ON/OFF buttons	ON/OFF buttons				
ALARM					yes	yes		yes
RESTORAL						yes		
PANIC	* [star buttons]	PANIC button	PANIC button	PANIC button			PANIC button	
AUX	yes			yes				
LOW BATT	yes	yes	yes	yes	yes	yes	yes	yes
TAMPER					yes (100-691)	yes		
SUPERVISION	yes				yes	yes	yes	

## RADIO DEVICES - OPERATION

**ALARM:** Any Ness Radio Device can operate on any zone 1–8 as programmed by P841E. The hardwired zones 1–8 continue to operate in parallel.

**TAMPER:** Radio Device Tamper is transmitted by the 100-662 Radio Reed Switch. This appears as Tamper Alarm number 5.

**LOW BATTERY REPORT:** Low battery alarms from radio devices are displayed by the keypad as Power Alarm 9 and Power Alarm 0.

**VIEW 9:** Displays low battery alarms from Radio Devices 1–8.

**VIEW 0:** Displays low battery alarms from Radio Keys 1–8.

## RELATED OPTIONS:

P41xxE 9E & 0E to map low battery alarms to Output Groups. Page 23.

P64E 9E & 0E to map low battery alarms to Contact ID channels. Page 31.

## INSTALLER'S TIP

How to program the D24 to operate the relay output with an RK4 Radio Key AUX button. (2sec pulse on operation). Useful for garage door operators etc.

1. Program one or more RK4s to the panel using the instructions on the next page.
2. P811E 3E Makes timer group1
3. P802E 6E Makes group2 including Relay (Aux2 output on D24)
4. P95E 2E Two second timer
5. P422E 1E Initialises the TIMER
6. P401E 0E Assigns Output 1 to System 0 = Aux button

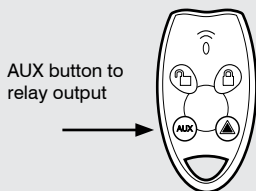

# NESS RADIO

**The optional 100–200 Ness Radio Interface is required for radio operation.**

OPTION No	DESCRIPTION	OPTION
P83E	CLEAR Radio Keys 1-8	Select 1E - 8E
P831E	Program Radio Keys 1-8	Select 1E - 8E
P84E	CLEAR Radio Devices 1-8	Select 1E - 8E
P841E	Program Radio Devices 1-8	Select 1E - 8E

## P83E, P831E

**PROGRAM MODE LEVEL:**  
Installer, Remote by PC

**FACTORY DEFAULT:**  
No Radio Keys programmed

- NOTES:**
- The 8 Radio Codes operate independently, they do not replace any keypad codes.
  - Radio Key programming is done by 'learning' the code by radio.
  - If a Radio Key is lost or misplaced, its use can be prevented by clearing that Radio Code using the keypad.
  - Radio Keys are allocated to User Codes 1–8, so that Open/Close reports are identified by user number when the control panel is central station monitored. (If Open/Close reports are enabled).

**RELATED OPTIONS:**  
P82E 3E Enable Radio Interface  
P34E 2E Enable Siren Chirps

## RADIO KEY PROGRAMMING

A total of eight Ness 100-664 Radio Keys can be programmed. The Radio Keys operate in conjunction with D24 User Codes 1 to 8 and, if monitored, are reported as User Codes 1–8 to the central station.

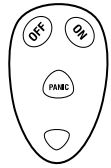

Press and hold Panic to send the learn message

### TO PROGRAM:

- Press **P831E**, then select a radio key to program. 1E–8E.
- On the Radio Key to be programmed, press and hold the **PANIC** button for 8 seconds.
  - The MEMORY light will flash during the 8 second 'Learn' transmission. If the Radio Key is accepted, the MEMORY light will turn on steady and 3 beeps will sound.
  - If the MEMORY light does not flash, the Radio Key is already programmed and must be cleared before it can be programmed again.

### TO CLEAR (DELETE) A RADIO KEY:

- Press **P83E**  
Lights 1–8 will show which Radio Keys are currently programmed.
- Press **1E–8E**  
Press the Radio Key number followed by E.

## P84E, P841E

**PROGRAM MODE LEVEL:**  
Installer, Remote by PC

**FACTORY DEFAULT:**  
No Radio Devices programmed

- NOTES:**
- Radio Device programming is done by 'learning' the code by radio.
  - If a Radio Device is lost or misplaced, its use can be prevented by clearing that Radio Code using the keypad
  - The device's ENCR link (if fitted) must be off. This applies to the 100-663 Radio PIR and the 100-662 Radio Reed Sw.

**RELATED OPTIONS:**  
P82E 3E Enable Radio Interface

## RADIO DEVICE PROGRAMMING

A total of eight Ness Radio Devices can be programmed.

A Radio Device is any type of Ness transmitter including Radio PIR, Radio Reed Switches, Radio Smoke Detector.

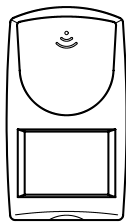

Insert battery to send the learn message

### TO PROGRAM:

- Press **P841E**, then select a radio device to program. 1E–8E.
- Trigger the Radio Device (or insert the battery).
  - If the Radio Device is accepted, the MEMORY light will turn on steady and 3 beeps will sound.
  - If the MEMORY light does not flash, the Radio Device is already programmed and must be cleared before it can be programmed again.
  - When the device has been programmed, remove its battery to prevent it from transmitting while you program the next device. *Remember to replace all the batteries when finished programming.*

### TO CLEAR (DELETE) A RADIO DEVICE:

- Press **P84E**  
Lights 1–8 will show which Radio Devices are currently programmed.
- Press **1E–8E**  
Press the Radio Device number followed by E.



Press 3 times to send the learn message

## NESS RADIO

OPTION No	DESCRIPTION	Zones	1	2	3	4	5	6	7	8
P85E	Supervised Radio Zones									
P86E	Radio Supervision time		0 hours							

### P85E

**PROGRAM MODE LEVEL:**

Installer, Remote by PC

**FACTORY DEFAULT:**

no zones

**TO PROGRAM:**

P85E [zone] E [zone] E ... etc

*Toggles the option ON and OFF.*

**NOTE:**

Older Radio PIRs without a supervision option should not be used on supervision-enabled zones.

### SUPERVISED RADIO ZONES

This option assigns zones that will operate as Radio Supervised types. This applies to zones 1-8 only.

Supervised signals failure reports a Contact ID code 381 for that zone. The report is sent once only.

The keypad will indicate Radio Supervision by flashing the System icon and continuous beeping.

### P86E

**PROGRAM MODE LEVEL:**

Installer, Remote by PC

**FACTORY DEFAULT:**

0 hours (disabled)

**TO PROGRAM:**

P86E [0-24 hours] E

### RADIO SUPERVISION TIME

The SUPERVISION TIME is the time allowed between radio transmissions received by the panel from any Supervised Ness Radio PIR (100-663, 100-691).

The SUPERVISION TIME setting is from 01 to 24 hours.

# NESS RADIO

OPTION No	DESCRIPTION	DEFAULT
P93E	Medical Delay	0 hours

## P93E

### PROGRAM MODE LEVEL:

Installer, Remote by PC

### FACTORY DEFAULT:

0 hours (disabled)

### TO PROGRAM:

P86E [0-48 hours] E

### RELATED OPTIONS:

P40xxE 7E To map the Medical Alarm to an Output Group. Default is Output Group 30 (Sonalert + dialler). See page 23.

Medical Alarm Operation, page 45.

## MEDICAL DELAY

Any 24 hour zone or Key switch input or Panic input may be used to control Medical alarm by assigning the chosen input to Output Group 16.

**A. Instant Medical Alarm:** Immediately sound the sirens and send a Medical Alarm report to the Central Monitoring Station. (The Medical Alarm Delay must be set at zero hours).

**B. Inactivity Medical Alarm:** The Medical Alarm is reported if the Medical Alarm button is NOT pressed within the pre-programmed Medical Alarm Delay. (The Medical Alarm Delay can be set between 1 and 48 hours).

### INSTANT MEDICAL ALARM - OPERATION

1. If the Medical Alarm Delay is not being used, simply press the designated Medical Alarm button.
2. If the Medical Alarm Delay is being used, an instant Medical Alarm can be sent by pressing the button twice within 12 seconds. On the first press, the keypad/s will beep once per second during the 12 second period. On the second press, the keypad/s will beep fast to indicate that the Medical Alarm has been reported.

### INACTIVITY MEDICAL ALARM - OPERATION

The Inactivity Medical Alarm can be used to summon assistance if a person has become incapacitated and is not able to press their Medical Alarm button.

For example, if the Medical Alarm Delay is set for 24 hours, the Medical Alarm will be triggered if the button is not pressed every 24 hours.

When 20 minutes of the Medical Alarm Delay time remains, and the Medical Alarm button has not been pressed, the keypad/s will beep for 10 seconds as a reminder.

As a final warning that the Medical Alarm delay is due to expire, the keypad/s will beep continuously during the final 10 minutes.

## PROGRAMMING

OPTION No	DESCRIPTION	DEFAULT
P94E	General Purpose Timer Delay	0 sec
P95E	General Purpose Timer Duration	0 sec

### P94E, P95E

**PROGRAM MODE LEVEL:**

Installer, Remote by PC

**FACTORY DEFAULT:**

P94E: 0 sec (disabled)

P95E: 0 sec (disabled)

**TO PROGRAM:**

P94E [time] E

P95E [time] E

(Enter 0–100 seconds or 101–220 for 1–120 minutes)

**RELATED OPTIONS:**

P42xxE 1E To map the GPT to an Output Group. See page 23.

**NOTE:**

If you program the timer to control an output, the timer will take priority over any other function. For example, if you program the timer to pulse the Siren for 10 seconds, and the siren has been triggered by a zone to run for the Reset time i.e. 10 minutes, the Siren will turn off after 10 seconds. The Timer should only be used to operate on unused outputs wherever possible to save confusion.

### GENERAL PURPOSE TIMER

The General Purpose Timer (GPT) is a versatile extra timer which can be used along with all the other standard features of the D24 to turn on an extra output for a pre-determined period of time with an optional pre-alarm delay.

The GPT can be programmed to trigger from any alarm input of the D24 (whether that input is used for other functions or not) and can turn on for a maximum 120 minutes with a maximum pre-alarm delay of 120 minutes.

#### P94E TIMER DELAY

This is the time from the input ‘on’ to the start of the output pulse.

P94E [time] E

There are two time ranges.

Enter a value of 0–100 for 0–100 seconds.

Enter a value of 101–220 for 1 to 120 minutes.

#### P95E TIMER DURATION

Duration the Timer stays on.

P95E [time] E

There are two time ranges.

Enter a value of 0–100 for 0–100 seconds.

Enter a value of 101–220 for 1 to 120 minutes.

#### EXAMPLE:

To set up the timer to turn on the Relay for 1 hour with a pre-delay of 30 seconds when a Monitor Zone triggers.

1. Program the timer delay to 30 seconds. P 94 E 30 E.
2. Program the timer duration to 60 minutes. P 95 E 160 E.
3. Build up an Output Group which includes the Relay for the Timer to turn on. We will create Output Group 1 for the example. P 80 1 E 6 E
4. Program the timer to drive this output. P 42 1 E 1 E

Assign your zone inputs to trigger a monitor output which includes the timer selected (to do this you will need to build another Output Group, for this example we will create Output Group 2).

Build the Output Group: P 8 0 2 E 1 E 2 E 3 E 4 E P 8 1 2 E 1 E 3 E 4 E

Assign Monitor Zones (1-6) to output 2: P 3 7 2 E 1 E 2 E 3 E 4 E 5 E 6 E

OPTION No	DESCRIPTION	DEFAULT
P99E	Program Installer Code	000000

### P99E

**PROGRAM MODE LEVEL:**

Installer, Remote by PC

**FACTORY DEFAULT:**

000000

**TO PROGRAM:**

P99E [new code] E [new code] E

(3–6 digits)

### PROGRAMMING THE INSTALLER CODE

This option programs the Installer Code.

Factory default is 000000.



## PROGRAMMING

OPTION No	DESCRIPTION	DEFAULT
P96E	Code Retry Limit	2
P97E	Duress prefix	9

### P96E

**PROGRAM MODE LEVEL:**

Installer, Remote by PC

**FACTORY DEFAULT:**

2 retries

**TO PROGRAM:**

P96E [retries] E (0–9)

**RELATED OPTIONS:**

P40xxE 8E To map User Code Alarm to an Output Group. See page 23.

### P97E

**PROGRAM MODE LEVEL:**

Installer, Remote by PC

**FACTORY DEFAULT:**

9

**TO PROGRAM:**

P97E [duress prefix digit] E (0–9)

**RELATED OPTIONS:**

P40xxE 5E To map the Duress Alarm to an Output Group. See page 23.

### CODE RETRY LIMIT

The number of retries to enter a valid code may be set from 1 to 9.

A value of 0 disables the alarm.

Factory default is 2 retries, (alarms on the second retry).

### DURESS PREFIX

To Disarm and simultaneously send a DURESS alarm, prefix a user code with the “Duress Digit” when Disarming.

The Duress Digit can be any number from 0–9. Factory default is 9.

Important - if the Duress Prefix is to be changed, be careful that you do not get an access code of [Duress Prefix + another access code]. This can only happen if access codes of mixed length are used and the Duress Prefix is changed after programming access codes.

OPTION No	DESCRIPTION
P981E	Default panel options Except Dialler, User Codes, Installer code and Entry/Exit delays
P982E	Default User Codes, Installer code & Entry/Exit delays
P983E	Default dialler options
P984E	Clear Alarm Memory
P985E	Clear dialler buffer

### P98xE

**PROGRAM MODE LEVEL:**

Installer, Remote by PC

**FACTORY DEFAULT:**

as per Options Summary

**TO PROGRAM:**

P [98x] E

### FACTORY DEFAULTS

Reset various programming options to factory default.

**P981E: DEFAULT PANEL OPTIONS**

Resets to factory default all options except Dialler options, User and Installer Codes and Entry/Exit delays.

**P982E: DEFAULT USER CODES, INSTALLER CODE & ENTRY/EXIT DELAYS**

Resets to factory default all User Codes, Installer Code and Entry/Exit delays.

**P983E: DEFAULT DIALLER OPTIONS**

Resets to factory default all Dialler options.

**P984E: CLEAR ALARM MEMORY**

Clears all events from the alarm memory.

**P985E: CLEAR DIALLER BUFFER**

Clears all outstanding alarm messages queue in the dialler buffer.

**PROGRAM OPTIONS SUMMARY**

Pages 54, 55

## OPERATION

### OPERATING MODES

The Ness D24 will operate in one of the following modes:

**ARMED:** The system is “On” and ready to detect intrusion. 24 Hour Zones (if configured) are still active. Area Partitioning means the panel can be split into three separate “Areas” which can be Armed and Disarmed independently of each other.

**DISARMED:** The system is “Off”. This is the normal mode when the premises are occupied. Day Zones and 24 Hour Zones (if configured) are still active.





**DAY Mode:** The system is *Disarmed* and a zone or zones have been setup to create an alarm when activated. Often used as a doorway alert in a shop.



**MONITOR Mode:** Allows the system to be “partially” Armed. For example, in a house, to allow all perimeter zones, doors and windows, to be Monitored (armed) at night.

**24HR Zones:** Zones that have been setup to be active in any mode. Usually used for Tamper switches and Panic buttons.

### ARMING THE SYSTEM

If the D24 has not been programmed for Area operation, this method will Arm the entire system.

Press...  (If Two Button Keypad Operation is disabled. This is the factory default.)  
 ...or   (If Two Button Keypad Operation is enabled.)  
 ...or  [CODE]  (If Shortcut Arming is disabled.)

Three beeps will sound  and the ARM icon will turn ON   
 Leave the premises within the Exit Delay Time.

At the end of Exit Delay Time, 1 beep will sound 

#### SIREN WARNING:

At the end of the exit time, all zones should be **Sealed**. If any are **Unsealed**, the siren will sound for 2 seconds as a warning to indicate that those zones have been automatically excluded. For maximum security, you should return, Disarm, check the premises and then Arm again. Continual warnings could mean that a detector is faulty and may have to be manually excluded.

#### AUTO EXCLUDE:

If the auto-exclude option is disabled, the siren will sound for the duration of reset time if a zone is Unsealed at the end of exit time.

#### ERROR BEEP WHEN DISARMING:

An error beep when attempting to Disarm may indicate:

- Incorrect Code
- or the panel is already Disarmed
- or the panel is in Exclude mode

### DISARMING THE SYSTEM

If the D24 has not been programmed for Area operation, this method will Disarm the entire system.

Press... [CODE] 

Three beeps will sound  and the ARM icon will turn OFF 





Disarm the panel during the Entry Delay Time to prevent unwanted “Alarm on entry”.

## OPERATION

Most users of the panel should be assigned Area Codes. An Area Code allows you to Arm and Disarm only the Area which has been assigned to that code. This makes Area operation as simple as possible with the least number of keystrokes.

### TO ARM YOUR AREA

Press... **ARM** [CODE] **E**

Three beeps will sound  and your AREA icon will turn ON  or  or   
Leave the Area within the Exit Delay Time. At the end of Exit Delay Time, 1 beep will sound 

### TO DISARM YOUR AREA

To Disarm the Area assigned to your code, simply enter your code followed by E.

Press... [CODE] **E**

Three beeps will sound  and the respective AREA icon will turn OFF  or  or 





### TO ARM AREAS USING AN ADMINISTRATOR CODE

Using an Administrator Code to Arm selected Areas.

Press... **AREA** 1, 2 or 3 **E** **ARM** [CODE] **E**\*

...or to Arm multiple Areas at once

**AREA** **1** **E** and/or **2** **E** and/or **3** **E** **ARM** [CODE] **E**

Three beeps will sound  and the selected AREA icon/s will turn ON  or  or   
Leave the Area within the Exit Delay Time. At the end of Exit Delay Time, 1 beep will sound 





### TO DISARM AREAS USING AN ADMINISTRATOR CODE

Using an Administrator Code to Disarm selected Areas.

Press... **AREA** 1, 2 or 3 **E** [CODE] **E**

...or to Disarm multiple Areas at once

**AREA** **1** **E** and/or **2** **E** and/or **3** **E** [CODE] **E**

Three beeps will sound  and the selected AREA icon/s will turn OFF  or  or 

...or a shortcut to Disarm all Areas

Press... [CODE] **E**

Three beeps will sound  and all AREA icons will turn OFF  or  or 

## OPERATION

### ZONES MUST BE SEALED

Make sure that all zones in the Monitor area are sealed before Arming Monitor mode.

### EXIT DELAY





The Exit Delay time applies to Monitor mode.

### MONITOR MODE ARMING

Monitor mode allows you to Arm selected zones while others are ignored. Typically used to monitor perimeter zones (doors and windows) while you are at home.











Your system may be programmed to give the choice of Arming two different Monitor areas (Dual Monitor mode), otherwise there is one Monitor area (Single Monitor mode).

#### ARMING SINGLE MONITOR MODE

Press...   
 ...or   ...or  [CODE] 

Three beeps will sound  and the MONITOR icon will flash constantly 

#### ARMING DUAL MONITOR MODE

Press...   ...or    
 ...or    ...or   

MONITOR 1 armed is indicated by the  icon flashing constantly.

MONITOR 2 armed is indicated by the  icon flashing constantly.



### PANIC ALARM

The keypad panic function may have been programmed to be either:

**Audible:** Activates siren or buzzers, or **Silent:** If Central Station monitored, sends a Panic report by dialler. (If Panic reports are enabled, P40xxE 6E).

Panic cannot be used while the panel is in Program, Memory or Exclude mode.

Keypad Panic alarm is number **6** in the  view.

Press...  (Press and hold for at least 1 second)  
 ...or   (If Two Button Keypad Operation is enabled)

### DURESS ALARM

A DURESS alarm can be triggered to alert the Central Monitoring Station that the user is being forced to Disarm the panel against their will.

To Disarm and simultaneously send a DURESS alarm, prefix any valid User Code with the "Duress Digit" when Disarming.

The factory default Duress Digit is 9. (It can be any number from 0-9).

By default, DURESS alarms do not sound any audible alarms, P40xxE 5E).

Duress alarm is number **5** in the  view.

Disarm by pressing... [DURESS DIGIT] [User Code] 

The panel Disarms as normal and the Duress report is sent to the Central Monitoring Station.



• IF DURESS ALARM IS USED, AVOID USER CODES THAT BEGIN WITH THE SAME NUMBER AS A DURESS DIGIT.

• DURESS ALARM CAN ONLY BE USED IF THE SYSTEM IS CENTRAL STATION MONITORED.

## OPERATION

This page is an extract from the D24 User Manual.

See Page 39 for Medical Delay programming.

### MEDICAL ALARM

Your system may have been setup with a Medical Alarm. This type of alarm can be used to summon assistance for the elderly or infirm who are living alone. A Medical Alarm is most effective if the system is monitored by a Central Monitoring Station.

Medical Alarms can be used in two ways:

1. **INSTANT MEDICAL ALARM:** Immediately sound the sirens and send a Medical Alarm report to the Central Monitoring Station. (In this case, the Medical Alarm Delay is set at zero hours).
2. **INACTIVITY MEDICAL ALARM:** The Medical Alarm is reported if the Medical Alarm button is NOT pressed within the pre-programmed *Medical Alarm Delay*. (In this case, the Medical Alarm Delay is set between 1 and 24 hours).

#### INSTANT MEDICAL ALARM

##### OPERATION

1. If the Medical Alarm Delay is not being used, simply press the designated Medical Alarm button.
2. If the Medical Alarm Delay *is* being used, an instant Medical Alarm can be sent by pressing the button twice within 12 seconds. On the first press, the keypad/s will beep once per second during the 12 second period. On the second press, the keypad/s will beep fast to indicate that the Medical Alarm has been reported.

#### INACTIVITY MEDICAL ALARM

##### OPERATION

The Inactivity Medical Alarm can be used to summon assistance if a person has become incapacitated and is not able to press their Medical Alarm button.

For example, if the Medical Alarm Delay is set for 24 hours, the Medical Alarm will be triggered if the button is not pressed every 24 hours. (Effectively, it is an, "I'm OK", button).

When 20 minutes of the Medical Alarm Delay time remains, and the Medical Alarm button has *not* been pressed, the keypad/s will beep for 10 seconds as a reminder.

As a final warning that the Medical Alarm delay is due to expire, the keypad/s will beep continuously during the final 10 minutes.

#### MEDICAL ALARM BUTTON

The Medical Alarm button can be setup to take the place of the keypad Panic button or it may be a separate button. This must be determined by your installer.

Medical alarm is number **7** in the  SYSTEM view.

### FIRE ALARM

Your system may have smoke detectors connected to 24 hour Fire inputs.

Fire inputs, (if enabled), are indicated by the Fire  icon on the keypad. Any zone can become a Fire input by mapping it to Output Group 26.

#### NOTE:

If Inactivity Medical Alarm is enabled, the client should give notice to their monitoring station if they plan to be absent from the premises for extended periods, (holidays, visits etc).

## OPERATION

### DEFAULT VIEW

The display always shows the zone menu by default.

It will automatically revert back to the ZONE menu after eight seconds if left in any other view menu.



This is the normal display while disarmed with no outstanding alarms. The ZONE icon is on as well as any number 1 to 24 if zones are being unsealed.

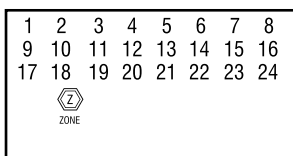

Zone numbers will be on only if there are unsealed zones or alarmed zones to view.

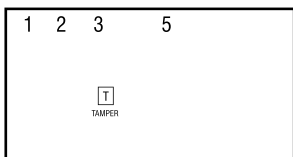

Tamper numbers will be on only if there are Tamper alarms to view.

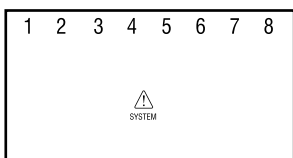

System numbers will be on only if there are System alarms to view.

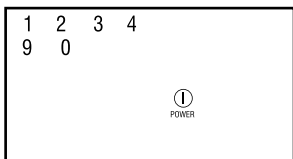

Power numbers will be on only if there are Power alarms to view.

### VIEW MENU

The VIEW menu can be used at any time to display the status of Zone, Tamper, System and Power inputs.

The status of these inputs can be displayed “live” as it happens, or as a previous event in Memory mode.

**TO VIEW A CURRENT ALARM:** Press... **VIEW**, the MEMORY icon will be on



and one of the system icons ZONE TAMPER SYSTEM POWER along with a number to indicate which alarm is present. If there is no current outstanding alarm, pressing VIEW from the normal zone display mode will display the last event.

**TO VIEW THE STATUS OF ALL ALARMS:** Press... **VIEW** [Repeat presses] Repeated presses of the VIEW button will cycle viewing of Zone, Tamper, System, Power and Memory sub-menus.

Or, each sub-menu can be directly viewed by pressing **VIEW** [1-6]

**TO VIEW ZONES** **PRESS...** **VIEW** **1**

The zone indicators 1-24 will show the state of the 24 zones and possibly one or more other icons flashing to indicate other alarms.

**TO VIEW TAMPERS** **PRESS...** **VIEW** **2**

Zone indicators will show the state of the four Tamper inputs:

**TAMPER 1:** External Tamper alarm.

**TAMPER 2:** Control Panel Tamper alarm.

**TAMPER 3:** Zone Input Tamper alarm.

**TAMPER 5:** Radio Interface Tamper alarm.

**TO VIEW SYSTEM** **PRESS...** **VIEW** **3**

Zone indicators will show the state of the eight System inputs:

**SYSTEM 1:** Keyswitch Panic

**SYSTEM 2:** Dialler line fault

**SYSTEM 3:** Keypad connection fault

**SYSTEM 4:** Control panel fault

**SYSTEM 5:** Duress Alarm

**SYSTEM 6:** Panic Alarm

**SYSTEM 7:** Medical Alarm

**SYSTEM 8:** User Code Alarm

**SYSTEM 9:** Access to Installer Program mode

**TO VIEW POWER** **PRESS...** **VIEW** **4**

Zone indicators will show the state of the six Power alarms:

**POWER 1:** Mains power failure

**POWER 2:** Control panel backup battery is low

**POWER 3:** DC supply failure

**POWER 4:** Zone reference power failure

**POWER 9:** Radio device battery low. (Zone indicators 1-8 will show which device)

**POWER 0:** Radio Key battery low. (Zone indicators 1-8 will show which Radio Key)

# OPERATION



## HOW TO VIEW MEMORY

1. When the icon is flashing to indicate there is a new alarm in memory, pressing **VIEW** will display an icon, (for example, Zone, Tamper, System etc), and a number to indicate the type of alarm.
2. In normal idle mode, (system is disarmed with the icon displayed), the memory history can be displayed in sequence.

To view the Memory History, Press... **VIEW** the icon will turn on.

Then press... **VIEW** [Repeat presses]. At each step, the keypad icons will display past events. The Zone, Tamper, System and Power icons will indicate what type of events are being displayed.

Memory is displayed backwards from most recent event to the end of memory. The past 50 events are stored.

Press **E** to exit the Memory menu.

## EVENTS INDICATED BY KEYPAD ICONS:

ICON	EVENT
MEMORY	Events are from memory
ZONE & 1-24 [flashing]	Zone alarms
TAMPER & 1-5	Tamper alarms
SYSTEM & 1-8	System alarms
POWER & 1-0	Power alarms
FIRE & 1-24 [flashing]	Fire Zone alarm
ARM	Arm
ZONE	Disarm
MONITOR [slow flash]	Monitor Mode
AREA 1	Area 1 Arm
AREA 2	Area 2 Arm
AREA 3	Area 3 Arm
AREA 1 [slow flash]	Area 1 Monitor Mode
AREA 2 [slow flash]	Area 2 Monitor Mode

Example: How to view Memory and the types of events that might be shown.

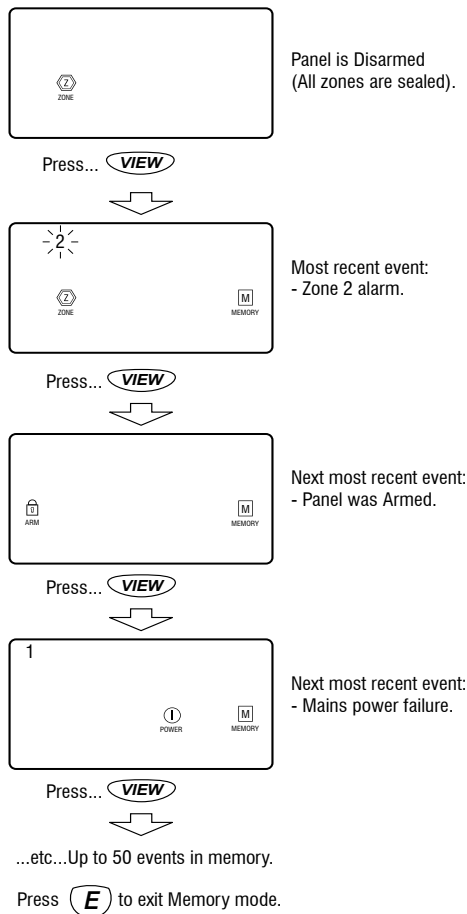

## OPERATION

### EXCLUDING ZONES

Zones and other inputs can be Excluded so that it does not generate alarms. EXCLUDE is a method of temporarily disabling an input.



When zones have been Excluded, the EXCLUDE icon flashes continuously while the panel is Disarmed and also when Armed.



Zones can only be Excluded when the panel is Disarmed.

Zone Exclude is **not permanent**. Excluded zones are automatically INCLUDED next time the panel is Disarmed.

Zones can be manually included by the same method as Excluding. In Exclude mode, simply use the [NUMBER]  sequence to turn OFF the zone lights to be Included.

#### TO ENTER EXCLUDE MODE

Press...  [CODE] 

...or   (If Shortcut Exclude is enabled)

#### TO EXCLUDE ZONES

  will be on) Press... [ZONE NUMBER]  [ZONE NUMBER]  ...etc

The selected Zone numbers will turn on.

#### TO EXCLUDE TAMPER ALARMS

Press...  2   (EXCLUDE and TAMPER will be on) [TAMPER NUMBER]  ...etc

The selected Tamper numbers will turn on.

#### TO EXCLUDE SYSTEM ALARMS

Press...  3   (EXCLUDE and SYSTEM will be on) [SYSTEM NUMBER]  ...etc

The selected System numbers will turn on.

#### TO EXCLUDE POWER ALARMS

Press...  4   (EXCLUDE and POWER will be on) [POWER NUMBER]  ...etc

The selected Power numbers will turn on.

#### TO EXIT EXCLUDE MODE

Press...   (EXCLUDE will flash while Disarmed and Armed)



## OPERATION

### TEST MODE

Test Mode allows the user to manually test all audible and visual outputs without alarming the panel.

In normal operating mode, Press... [CODE] **E** The <sup>?</sup>TEST icon will turn on.

Press the keys below to operate each output. Press the same key to turn the output off. Pressing any other key will test that output and cancel the current output.

Press... **E** To exit Siren test mode.

KEY	INDICATOR	OUTPUT
1	1	SIREN A, Tone 1
2	2	SIREN B, Tone 1
3	3	RESET (internal screamer)
4	4	STROBE
5	5	AUX 1
6	6	AUX 2
7	7	KEYPAD BEEPS
8	1	SIREN A, Tone 2
9	2	SIREN B, Tone 2

### TEST OPTIONS

This section is repeated on page 26.

#### P45E 1E INSTALLATION WALK TEST MODE.

This test runs in installer program mode while P45E 1E is selected. Outside of installer program mode, the test is suspended but the zone selection remains.

ON: Installation Walk Test Mode is enabled.

To enter test mode, press **P45E 1E** The <sup>?</sup>TEST icon will fast flash.

**[zone number] E, [zone number] E...** select (or de-select) the zones to test  
As each zone is selected, the corresponding zone icon will turn on.

Each test zone will now, on going unsealed, cause its zone indicator to fast flash and the Reset output to give a 2 second burst.

To cancel the walk test press the **E** button.

To restart the walk test, press **1E**, The <sup>?</sup>TEST icon will resume flashing. The previously selected test zones will be on.

#### P45E 2E AUTOMATIC ZONE TEST.

This test can identify potentially faulty detection devices by alerting the user to zones which have not unsealed during the past 20 Arm and Disarm cycles.

If selected, the test runs during the normal operation of the panel.

If any non-24hr zone/s does not unseal during 20 Arming cycles, the D24 will alert the user by turning on the <sup>?</sup>TEST icon.

You can view the offending Zone(s) by pressing **VIEW 7**. The offending zone(s) icons will be ON.

To clear the Zone Test label, unseal the offending zone(s) while still in the **VIEW 7** mode. This will result in the steady zone icon changing to a fast flash. This will verify whether the zone is functioning correctly or not.

To cancel the display press the **E** button.

If the <sup>?</sup>TEST icon remains on, press **VIEW 7** then **E**.

## MONITORING

### CENTRAL STATION MONITORING

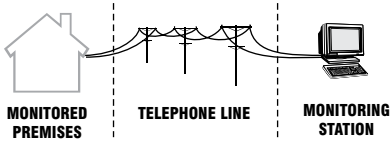

### CENTRAL STATION MONITORING P54E 3E enabled (Default)

The Ness D24 control panel has an on-board digital dialler which can send detailed alarm messages to a Central Monitoring Station.

The digital messages can include information about the zone/s which caused the alarm, tamper alarms, low battery or mains failure reports, and it can also (by user number) identify the users who Arm and Disarm the system.

Central Station Monitoring is highly recommended and is the most effective method of monitoring your alarm system.

Installers are welcome to contact Ness for further information about monitoring.

### AUDIBLE MONITORING

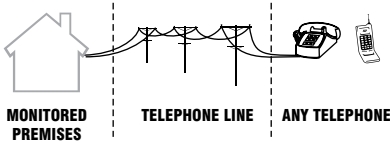

### AUDIBLE MONITORING P54E 2E enabled

While Central Station Monitoring is recommended, the D24 can also send audible voice alarm reports to any telephone. The audible voice message repeats the word "ALARM".

#### REPORTING SEQUENCE

When triggered by an alarm event the D24 will call the Primary Telephone Number (P51E) and then commence the audible message, the audible message will continue for 45 seconds or until it is acknowledged by the # key on the telephone.

If there is more than one alarm message to transmit, after it has received the Kiss-off/ Acknowledge tone it will commence transmission of the next message. The D24 should continue to do this until all alarm messages are transmitted and Kissed-off.

#### ACKNOWLEDGE TONE

The person receiving the call can then acknowledge the alarm by pressing the # key on their telephone. Press the # key for at least 2 seconds during pauses in the audible message.

*Audible Voice format is available in D24 V1.5 and later.*

## REMOTE OPERATION BY TELEPHONE

### AUDIBLE FEEDBACK

#### 3 BEEPS:

- The User Code is valid
- Successful Arming or Disarming
- An Auxiliary output has been turned ON.

#### 1 LONG BEEP:

- The panel is already Armed
- Invalid code. Try again.

#### 1 SHORT BEEP:

- An Auxiliary output has been turned OFF.

### TELEPHONE COMMANDS

**0** Prepare to receive commands

**0 #** Arm the panel\*

**1 #** Arm Area 1

**2 #** Arm Area 2

**3 #** Arm Area 3

**4 #** Turn Aux 1 Output ON or OFF

**5 #** Turn Aux 2 Output ON or OFF

**9 9 #** Disarm all Areas

**\* #** Finished - hang up

\* The OE command arms the Admin Area. This means, if there are no areas programmed, it arms the whole panel. If areas have been programmed, OE arms any zones that remain in the Admin area, (i.e. zones that have not been allocated to any area).

### RELATED OPTIONS:

**P58E 3E** Enable remote ADMIN. Arm

**P58E 4E** Enable remote AREA 1 Arm

**P58E 5E** Enable remote AREA 2 Arm

**P58E 6E** Enable remote AREA 3 Arm

**P58E 7E** Enable remote AUX1, AUX2

**P58E 8E** Enable remote Disarm all Areas

## OPERATING THE D24 BY TELEPHONE

The D24 control panel will allow a user to call in to the panel, using a standard DTMF telephone, and remotely Arm or Disarm all areas and also turn on or off Aux 1 and Aux 2.

To maintain panel security, remote operations can only be carried out after entering a valid user code.

To operate the panel by telephone, you need a DTMF capable telephone, a valid User Code and you must know the Telephone number of the line to which the panel is connected.

### NOTES

1. If the D24 does not receive commands for periods longer than 10 seconds it will assume that the call is finished and it will hang up.
2. You can keep the panel on line by regularly pressing the **0** button on the telephone.
3. If an alarm occurs which requires the D24 to dial out, the D24 will treat the alarm as a priority, give a constant tone as a warning and then hang up. It will then pick up the line again to report the alarm as programmed.
4. When all remote control commands are finished press **\* #** to force the D24 to hang up.

### OPERATION.

1. Phone the D24 telephone number and listen for the required number of rings (ring ring...ring ring) and then hang up. (Default is 1 ring).
2. Call the number again within 60 seconds.
3. The D24 will answer the second call immediately, sound a beep for 2 seconds then, after a pause, it will sound a lower frequency tone. The panel is now ready to receive telephone commands.
4. Press the **0** button on the telephone. This tells the D24 that telephone commands will follow. The D24 will respond with either 3 beeps if all OK or one long beep to try again.
5. Now enter a valid User Code followed by the **#** button. (Use a code that is normally used for Arming or Disarming the D24).  
  
The D24 will respond with 3 beeps if it recognises the code or 1 long beep to signal the code was invalid and to try again.
6. Enter the required command. See: Summary Of Telephone Commands.
7. Press **\* #** to finish. This tells the D24 to hang up. Also hang up your telephone.

## D24 OUTPUT EXPANDER

### CONNECTION

The Output Expander is wired to the D24 using only 3 wires as shown below.

AUX on the D24 is the serial data connection to the Output Expander. When the Output Expander is connected and enabled, the function of the D24 AUX output is provided by the AUX1 output on the Output Expander.

CONNECTION TABLE

OUTPUT EXPANDER	D24
+12V	+12V
0V	0V
AUX IN	AUX

### OUTPUTS

The open collector outputs can sink 100mA each and can be safely connected together for 'OR' operation.

The relay output has changeover N.O. & N.C. contacts rated at 2A.

The maximum current load available from the fused 12V DC output is 1.5 Amp.

### OUTPUTS OPERATION

All zone and emergency outputs latch on alarm and are cleared by Arming, Disarming or a Code entry. All other outputs follow their input states.

See the Outputs Operation Table.

OUTPUTS OPERATION TABLE

OUTPUTS	OPERATION
Zone alarms 1~24	Latching outputs.
Duress / Keypad Panic	Cleared on Arming, Disarming or Code Entry
Panic / Medical	
Tamper	
Radio Low Battery	
Admin. Area Armed	
Areas 1~3 Armed	Follow input state
Mains Fail	
Low Battery	
RELAY	Follows trigger state

The optional D24 Output Expander connects to the D24 control panel to provide 35 open collector outputs and 1 relay output.

The outputs can be used to drive mimic displays, provide additional outputs on alarm and various other custom purposes.

The Output Expander board interfaces with the D24 by three wire serial connection. The board is designed to fit inside the D24 control panel housing.

### PROGRAMMING

To become active, the Output Expander must be enabled by the D24 programming option P82E 4E.

**P82E 4E** toggles the option ON and OFF

**P82E 4E OFF:** Output Expander is DISABLED

**P82E 4E ON:** Output Expander is ENABLED

### CONNECTION TO THE D24

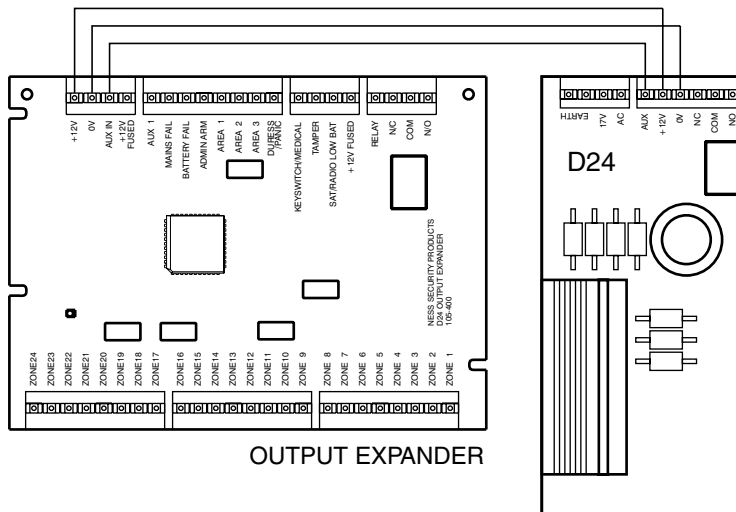

### INSTALLATION IN THE D24 BASE

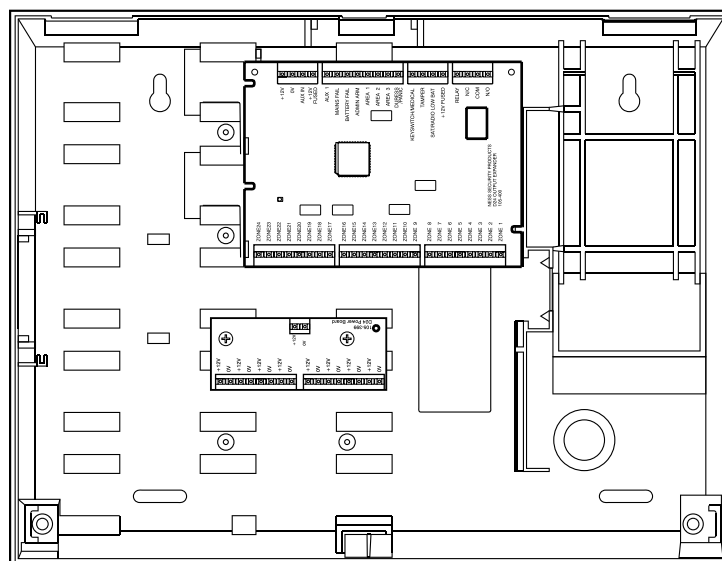



OPTION	DESCRIPTION	DEFAULT	PAGE
P1E	User Code 1 (Master Code)		14
P2E	User Code 2		
P3E	User Code 3		
P4E	User Code 4		
P5E	User Code 5		
P6E	User Code 6		
P7E	User Code 7		
P8E	User Code 8		
P9E	User Code 9		
P10E	User Code 10		
P11E	User Code 11		
P12E	User Code 12		
P13E	User Code 13		
P14E	User Code 14		
P15E	User Code 15		
P16E	User Code 16		
P017E	User Code 17		
P018E	User Code 18		
P019E	User Code 19		
P020E	User Code 20		
P021E	User Code 21		
P022E	User Code 22		
P023E	User Code 23		
P024E	User Code 24		
P025E	User Code 25		
P026E	User Code 26		
P027E	User Code 27		
P028E	User Code 28		
P029E	User Code 29		
P030E	User Code 30		

P17E	<b>Entry Delay Time</b>	20 Sec	15
P170E	Entry Delay Time <small>for zones in multiple areas</small>	20 Sec	
P171E	Entry Delay Time for AREA 1	20 Sec	
P172E	Entry Delay Time for AREA 2	20 Sec	
P173E	Entry Delay Time for AREA 3	20 Sec	
P18E	<b>Exit Delay Time</b>	60 Sec	
P181E	Exit Delay Time for AREA 1	60 Sec	
P182E	Exit Delay Time for AREA 2	60 Sec	
P183E	Exit Delay Time for AREA 3	60 Sec	

P19E	Security Delay zones	none	16
P20E	<b>Instant zones</b>	3 to 24	
P21E	<b>Entry Delay zones</b>	zone 1	
P22E	<b>Handover zones</b>	zone 2	
P23E	Secondary delay zones	none	
P271E	Single trigger zones	all zones	
P272E	Double trigger zones	none	

OPTION	DESCRIPTION	DEFAULT	PAGE
P251E-P258E	Zone response time	all zones P254E	17
P261E-P268E	Vibration sensitivity	none	17

P28E	<b>Siren Reset Time</b>	10 minutes	15
------	-------------------------	------------	----

P291E	Siren Lockout zones	all zones	18
P292E	Siren Lockout Tamper alarms	all	
P293E	Siren Lockout System alarms	all	
P294E	Siren Lockout Power alarms	all	
P301E	Excludable zones	all zones	18
P302E	Excludable Tamper alarms	all	
P303E	Excludable System alarms	all	
P304E	Excludable Power alarms	all	

P310E	Assign zones to ADMIN. AREA	all zones	19
P311E	<b>Assign zones to AREA 1</b>	none	
P312E	<b>Assign zones to AREA 2</b>	none	
P313E	<b>Assign zones to AREA 3</b>	none	
P321E	Assign zones to MONITOR 1	none	
P322E	Assign zones to MONITOR 2	none	

P33E	1E	Two button keypad operation	off	20
	2E	Shortcut ARMING	ON	
	3E	Shortcut EXCLUDE	ON	

P34E	1E	Keyswitch Unrestricted operation	off	21
	2E	Chirp Siren on K/S Arm/Disarm	off	
	3E	No Auto-Exclude	off	
	4E	<b>Entry Beeps</b>	ON	
	5E	[not used]	off	
	6E	Disable Zone Tamper	ON	
	7E	AUX1 Armed output	off	
	8E	'Zone Unsealed' warning on Arming	off	

**MAPPING ZONES & ALARMS TO OUTPUT GROUPS (xx=Output Group 0-31)**

P35 xxE	<b>Map Zones when ARMED</b>	all zones: P3517E	22
P36 xxE	Map Zones when DISARMED	all zones: P360E	
P37 xxE	Map Zones in MONITOR mode	all zones: P3720E	
P38 xxE	Map 24hr Zones	all zones: P380E	
P39 xxE	Map Tamper Alarms	all zones: P3927E	23
P40 xxE	Map System Alarms	various	
P41 xxE	Map Power Alarms	various	
P42 xxE 1E	Map General Purpose Timer	disabled: P420E	

**CREATE INSTALLER DEFINED OUTPUT GROUPS - METHOD 1**

P43 uuE yyE	Create installer defined Output Groups 1-15		25
-------------	---	--	----

P441E	Zones with no Exit Delay	none	26
P45E	1E	Installation WALK TEST (Select zones to test)	26
	2E	Enable Auto Zone Test	

OPTION	DESCRIPTION	DEFAULT	PAGE	
<b>DIALLER OPTIONS</b>				
<b>P50E</b>	<b>CLIENT CODE for central station</b>	0000	27	
<b>P51E</b>	<b>TELEPHONE NUMBER 1, Primary</b>	none	27	
<b>P52E</b>	Telephone Number 2, Secondary	none		
<b>P53E</b>	Telephone Number 3, Callback	none		
<b>P54E</b>	<b>1E</b>	off	28	
	<b>2E</b>	AUDIBLE VOICE reporting format		off
	<b>3E</b>	<b>CONTACT ID reporting format</b>		ON
<b>P55E</b>	<b>1E</b>	Auto Dialling Pulse & DTMF	ON	29
	<b>2E</b>	Pulse dialling always	off	
	<b>3E</b>	DTMF dialling always	off	
<b>P57E</b>	<b>1E</b>	Alternate dialling Pri/Sec Phone num	ON	29
	<b>2E</b>	Dial each Telephone number 5 times	off	
	<b>3E</b>	Repeat to Telephone number 2	off	
<b>P58E</b>	<b>1E</b>	Remote Command/callback Opt1	off	30
	<b>2E</b>	Remote Command/callback Opt2	off	
	<b>3E</b>	Enable remote Arm, ADMIN AREA	off	
	<b>4E</b>	Enable remote Arm, AREA 1	off	
	<b>5E</b>	Enable remote Arm, AREA 2	off	
	<b>6E</b>	Enable remote Arm, AREA 3	off	
	<b>7E</b>	Enable remote operation, AUX 1/2	off	
	<b>8E</b>	Enable remote Disarm, ALL AREAS	off	
<b>P59E</b>	Required Rings for auto-answer	1	30	
<b>P60E</b>	<b>1E</b>	<b>Enable Open/Close reports</b>	ON	30
	<b>2E</b>	Send ADMIN. Area O/C reports only	off	
	<b>3E</b>	Send Open/Close with P75xxE client codes	off	
	<b>4E</b>	Disable Open/Close reports	off	
<b>P61E</b>	Map Zones to Contact ID channels	Various, see page 31	31	
<b>P62E</b>	Map Tamper Alarms to Contact ID			
<b>P63E</b>	Map System Alarms to Contact ID			
<b>P64E</b>	Map Power Alarms to Contact ID			
<b>P65E</b>	<b>1E</b>	Disable multiple zone alarm reports	ON	32
	<b>2E</b>	Enable multiple zone alarm reports	off	
<b>P66E</b>	<b>1E</b>	Send Restorals after Siren Time	off	32
	<b>2E</b>	Send Restorals on Disarm	off	
	<b>3E</b>	Send Restorals immediately	ON	
	<b>4E</b>	Do not send Restorals	off	
<b>P67E</b>	Mains Fail reporting delay	60 minutes	32	
<b>P68E</b>	Abort Delay	30 seconds	33	
<b>P69E</b>	Abort Delay Zones	none		

OPTION	DESCRIPTION	DEFAULT	PAGE
<b>P70E</b>	Time before first Test Call	168 hours	33
<b>P71E</b>	<b>TEST CALL interval</b>	0 (disabled)	
<b>P72E</b>	<b>1E</b> Enable Easycall feature	off	34
<b>P73E</b>	Digits to dial after Opening	0 (disabled)	
<b>P74E</b>	Digits to dial after Closing	0 (disabled)	

ALTERNATE CLIENT CODES - Used when P60E 3E is ON.

<b>P750E</b>	ADMIN. Area Client Code	0000	35
<b>P751E</b>	AREA 1 Client Code	0000	
<b>P752E</b>	AREA 2 Client Code	0000	
<b>P753E</b>	AREA 3 Client Code	0000	

CREATE INSTALLER DEFINED OUTPUT GROUPS - METHOD 2

<b>P80 uuE yyE</b>	Installer defined Output Groups 1-15, Outputs 1-10		25
<b>P81 uuE yyE</b>	Installer defined Output Groups 1-15, Outputs 11-16		

<b>P82E</b>	<b>1E</b>	[not used]	off	35
	<b>2E</b>	<b>Enable Dialler</b>	ON	
	<b>3E</b>	<b>Enable Radio Interface</b>	off	
	<b>4E</b>	Enable Output Expander	off	

<b>P831E</b>	<b>PROGRAM Radio Keys</b> (Select Radio Key 1E-8E)		37
<b>P83E</b>	CLEAR Radio Keys (Select Radio Key 1E-8E)		
<b>P841E</b>	<b>PROGRAM Radio Devices</b> (Select Radio Device 1E-8E)		
<b>P84E</b>	CLEAR Radio Devices (Select Radio Device 1E-8E)		
<b>P85E</b>	Supervised Radio zones (Select Zones 1-8)		38
<b>P86E</b>	Radio Supervision Time (0-24hrs)	0 hrs (disabled)	

<b>P93E</b>	Medical Delay	0 hrs (disabled)	39
<b>P94E</b>	General Purpose Timer delay	0 sec (disabled)	40
<b>P95E</b>	General Purpose Timer duration	0 sec (disabled)	

<b>P96E</b>	Code retry limit	2	41
<b>P97E</b>	Duress prefix	9	

<b>P981E</b>	<b>Default panel options</b> (Except Dialler, Codes & delays)		41
<b>P982E</b>	Default User Codes, Installer code & Entry/Exit delays		
<b>P983E</b>	Default dialler options		
<b>P984E</b>	Clear Alarm Memory		
<b>P985E</b>	Clear dialler buffer		

<b>P99E</b>	Program Installer Code	000000	40
<b>P E</b>	Exit Program Mode		

These options are available in User Program Mode.

ALL options are available in Installer Program Mode



Date purchased:	Date installed:
Installation Company:	Phone:
Monitoring Company:	Phone::

# INSTALLATION RECORD

## Zone mapping

Zone	Description	Tick: on or off														Mapping zones to OUTPUT GROUP				Channel		
		P19E Security Delay	P20E Instant	P21E Entry Delay	P22E Handover	P23E Secondary Delay	P271E Single Trigger	P272E Double Trigger	P261E-P268E Vibration sensitivity	P291E Siren Lockout	P301E Excludable	P310E ADMIN Area	P311E AREA 1	P312E AREA 2	P313E AREA 3	P321E MONITOR 1	P322E MONITOR 2	P35xxE Armed state	P36xxE Disarmed state		P37xxE Monitor Mode	P38xxE 24hr
1																						
2																						
3																						
4																						
5																						
6																						
7																						
8																						
9																						
10																						
11																						
12																						
13																						
14																						
15																						
16																						
17																						
18																						
19																						
20																						
21																						
22																						
23																						
24																						

P17E Entry Delay Time	<input type="text"/>	Seconds	P50E Client Code	<input type="text"/>
P170E Entry Delay Time <small>for zones in multiple areas</small>	<input type="text"/>	Seconds	P51E Telephone Number 1	<input type="text"/>
P171E Entry Delay Time for AREA 1	<input type="text"/>	Seconds	P52E Telephone Number 2	<input type="text"/>
P172E Entry Delay Time for AREA 2	<input type="text"/>	Seconds	P59E Required rings for auto-answer	<input type="text"/>
P173E Entry Delay Time for AREA 3	<input type="text"/>	Seconds	P70E Time before first Test Call	<input type="text"/>
P18E Exit Delay Time	<input type="text"/>	Seconds	P71E Test Call interval	<input type="text"/>
P181E Exit Delay Time for AREA 1	<input type="text"/>	Seconds	P97E Duress prefix digit	<input type="text"/>
P182E Exit Delay Time for AREA 2	<input type="text"/>	Seconds		
P183E Exit Delay Time for AREA 3	<input type="text"/>	Seconds		
P28E Siren Time	<input type="text"/>	Minutes		



# INSTALLATION RECORD

## User Codes

OPTION No	USER CODE	MASTER CODE	AREA 1	AREA 2	AREA 3	RADIO KEY
P1E	User Code 1 (Master)					
P2E	User Code 2					
P3E	User Code 3					
P4E	User Code 4					
P5E	User Code 5					
P6E	User Code 6					
P7E	User Code 7					
P8E	User Code 8					
P9E	User Code 9					
P10E	User Code 10					
P11E	User Code 11					
P12E	User Code 12					
P13E	User Code 13					
P14E	User Code 14					
P15E	User Code 15					
P16E	User Code 16					
P017E	User Code 17					
P018E	User Code 18					
P019E	User Code 19					
P020E	User Code 20					
P021E	User Code 21					
P022E	User Code 22					
P023E	User Code 23					
P024E	User Code 24					
P025E	User Code 25					
P026E	User Code 26					
P027E	User Code 27					
P028E	User Code 28					
P029E	User Code 29					
P030E	User Code 30					

## Tamper Alarm mapping

	P292E Siren Lockout	P302E Excludable	P39xxE Map to Output Group	P62E Contact ID channel
<b>TAMPER ALARMS</b>	Tick: on or off		Output Group number	Channel
External Tamper <b>1E</b>				
Control Panel Tamper <b>2E</b>				
Zone input Tamper <b>3E</b>				
Radio Interface Tamper <b>5E</b>				

## System Alarm mapping

	P293E Siren Lockout	P303E Excludable	P40xxE Map to Output Group	P63E Contact ID channel
<b>SYSTEM ALARMS</b>	Tick: on or off		Output Group number	Channel
Keyswitch Panic <b>1E</b>				
Dialler line fault <b>2E</b>				
Keypad connection fault <b>3E</b>				
Control Panel fault <b>4E</b>				
Duress alarm <b>5E</b>				
Panic alarm <b>6E</b>				
Medical alarm <b>7E</b>				
User Code alarm <b>8E</b>				
Radio Supervision Alarm <b>9E</b>				
RK4 Radio Key AUX button <b>0E</b>				

## Power Alarm mapping

	P294E Siren Lockout	P304E Excludable	P41xxE Map to Output Group	P64E Contact ID channel
<b>POWER ALARMS</b>	Tick: on or off		Output Group number	Channel
Mains power failure <b>1E</b>				
Backup Battery low <b>2E</b>				
DC supply failed <b>3E</b>				
Zone reference supply failed <b>4E</b>				
Radio Device battery low <b>9E</b>				
Radio Key battery low <b>0E</b>				

## CONTACT ID REPORTING CODES

The panel reports alarms to the Central Station using Contact ID dialler format.

The message format is fixed as shown in this table.

### THE MESSAGE TAKES THE FORM OF:

**SSSS** Account Number  
**XYZ** Alarm type  
**GG** Group or Area designation  
**CCC** Alarm number

Event	SSSS	XYZ	GG	CCC
Burglary Zone	ssss 18	130	Note1	001 to 024
Keyswitch \ Panic	ssss 18	120	01	025
External tamper	ssss 18	137	01	026
Mains fail	ssss 18	301	01	027
Panel Low Battery	ssss 18	309	01	028
13.8 Volt Supply fail	ssss 18	307	01	029
Zone Reference Voltage fail	ssss 18	307	01	030
Telephone Line fail	ssss 18	350	01	031
Keypad Buss fail	ssss 18	307	01	032
Control Panel tamper	ssss 18	137	01	033
Control panel fault (diagnostic)	ssss 18	307	01	034
Duress alarm	ssss 18	121	01	035
24 Hour alarm (PANIC)	ssss 18	120	01	036
Medical alarm	ssss 18	100	01	037
Fire alarm	ssss 18	110	01	
Code alarm (retry limit exceeded)	ssss 18	137	01	038
Keyswitch tamper	ssss 18	144	01	047
Zone Circuit tamper	ssss 18	144	01	048
Access to Installer Program mode	ssss 18	306	01	056
Radio Low battery	ssss 18	384	01	300-307 Radio Keys 308 – 316 Radio PIRs, Radio Reeds etc
Automatic Test call	ssss 18	602	01	056
Radio Supervision	ssss 18	381	01	By Device ID
Radio Tamper (Device)	ssss 18	383	01	By Device ID
Auto Exclude	ssss 18	380	aa	By Device ID
Manual Exclude	ssss 18	573	aa	By Device ID
Open/Close with user ID	ssss 18	401	aa	By User ID
Radio Key panic	ssss 18	120	01	By User ID
Cancel of Alarm report	ssss 18	406	01	By User ID

Note1. If using area partition,  
Admin area = 08, Area 1 = 01, Area 2 = 02, Area 3 = 03



This page is intentionally blank